

P-15229

17722

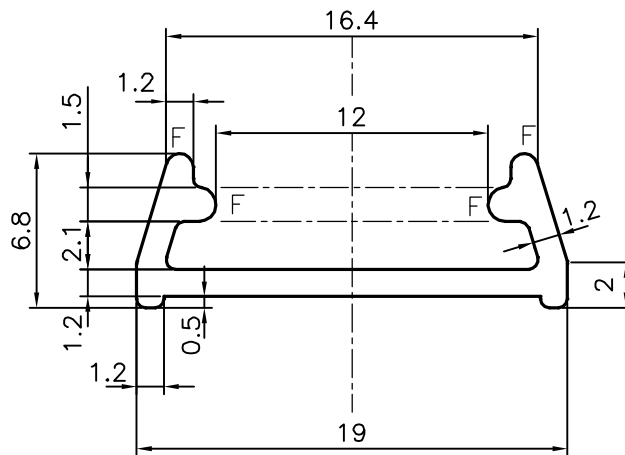

F = FULL RADIUS (4 PLACES)

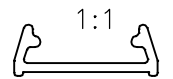

SYMBOL OF QUALITY
AN ISO 9001 COMPANY

JINDAL ALUMINIUM LTD.
BANGALORE-560073 (INDIA)

	NAME	DATE
DRAWN	J.P.KAUSHIK	10-10-2015
CHECKED		
APPROVED	S.S.GARG	15-10-2015
SCALE		3:1
AREA mm ²		40.616
PERIMETER mm.		64.69
WEIGHT kg/m		0.110
DRAWING No.	SECTION No.	
P-15229	-	
17722	17722	

1. ALL DIMENSIONS ARE IN mm.
2. ROUND OFF ALL SHARP CORNERS WITH 0.40 mm.
3. TOLERANCES WILL BE AS PER IS:3965-1981, UNLESS OTHERWISE SPECIFIED

PARTY'S NAME	GENERAL CATEGORY, BANGALORE MARKET
PARTY'S DRAWING No.	AS PER SAMPLE
ALLOY & TEMPER	HE9 WP
DESCRIPTION	TRANSPORT SECTION