

P-16759

17731

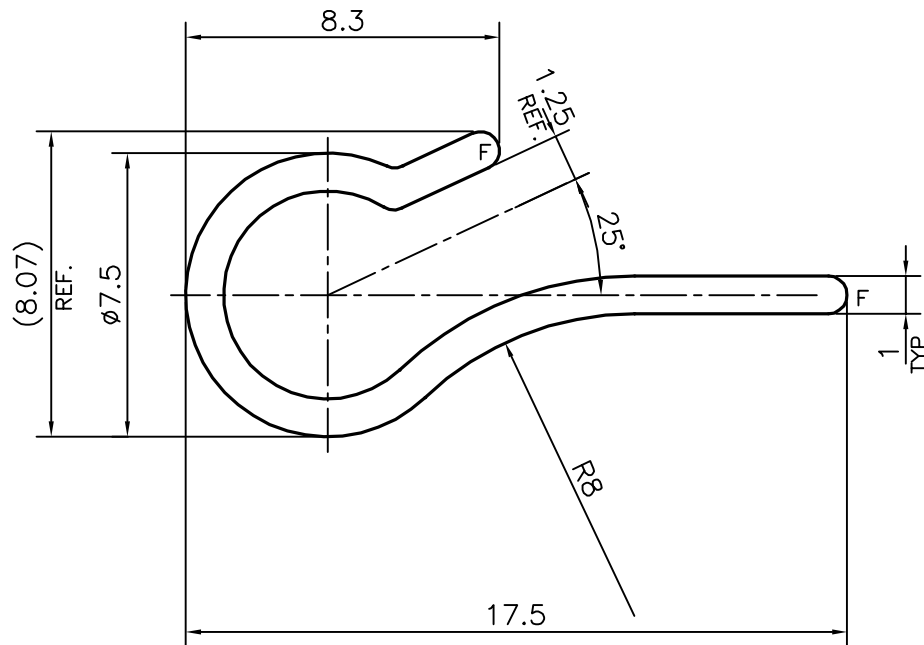

SCALE:- 1:1



F = FULL RADIUS (2 PLACES)

## TOLERANCES ON OVERALL WIDTHS &amp; WIDTHS ACROSS FLATS OF BARS, &amp; REGULAR SECTIONS

UPTO 6.40mm - ±0.20	UPTO 32.0mm - ±0.38	UPTO 120.0mm - ±0.85	1. STRAIGHTNESS=1.7mm/M 2. TWIST=1.7mm/M 3. ANGULARITY= ±2° 4. FLATNESS =0.007xWIDTH
UPTO 10.0mm - ±0.23	UPTO 50.0mm - ±0.46	UPTO 160.0mm - ±1.02	
UPTO 12.0mm - ±0.25	UPTO 60.0mm - ±0.53	UPTO 200.0mm - ±1.14	
UPTO 16.0mm - ±0.28	UPTO 80.0mm - ±0.69	UPTO 250.0mm - ±1.40	
UPTO 25.0mm - ±0.30	UPTO 100.0mm - ±0.75	UPTO 300.0mm - ±1.65	



SYMBOL OF QUALITY  
AN ISO 9001 COMPANY

**JINDAL ALUMINIUM LTD.**  
BANGALORE-560073 (INDIA)

	NAME	DATE
DRAWN	PARVESH	21-01-2017
CHECKED		
APPROVED	B.NATARAJ	30-01-2017

1. ALL DIMENSIONS ARE IN mm.
2. ROUND OFF ALL SHARP CORNERS WITH 0.50 mm.
3. TOLERANCES WILL BE AS PER IS:3965-1981, UNLESS OTHERWISE SPECIFIED

SCALE	5:1
AREA mm <sup>2</sup>	29.47
PERIMETER mm.	60.442
WEIGHT kg/m	0.080
DRAWING No.	SECTION No.

PARTY'S NAME GENERAL CATEGORY, MUMBAI MARKET

PARTY'S DRAWING No. AS PER SAMPLE

ALLOY & TEMPER HE9 WP

DESCRIPTION MISC. SECTION

P-16759

17731

17731