

P-14356

X1833

17732

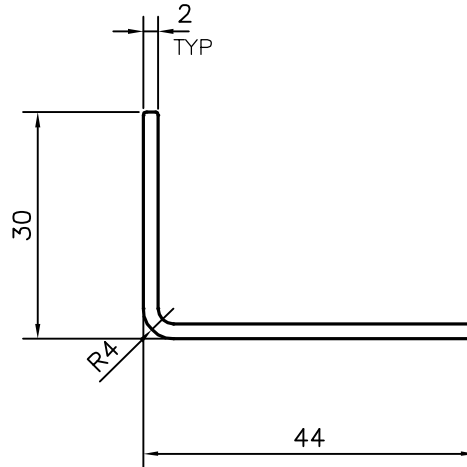

SYMBOL OF QUALITY
AN ISO 9001 COMPANY

JINDAL ALUMINIUM LTD.
BANGALORE-560073 (INDIA)

	NAME	DATE
DRAWN	J.P.KAUSHIK	21-01-2015
CHECKED		
APPROVED	S.S.GARG	29-01-2015
SCALE		1:1
AREA mm ²		141.287
PERIMETER mm.		144.738
WEIGHT kg/m		0.381
DRAWING No.	SECTION No.	
P-14356	-	
X1833	X1833	
17732	17732	

1. ALL DIMENSIONS ARE IN mm.
2. ROUND OFF ALL SHARP CORNERS WITH 0.40 mm.
3. TOLERANCES WILL BE AS PER IS:3965-1981 , UNLESS OTHERWISE SPECIFIED

PARTY'S NAME	PRESSTON ENGINEERING CORPORATION, BANGALORE
PARTY'S DRAWING No.	RFP81001CX0-D1 TYPE-02 & R
ALLOY & TEMPER	6063 T5
DESCRIPTION	UNEQUALE ANGLE- BRACKET SECTION