

P-15913

S4959

17750

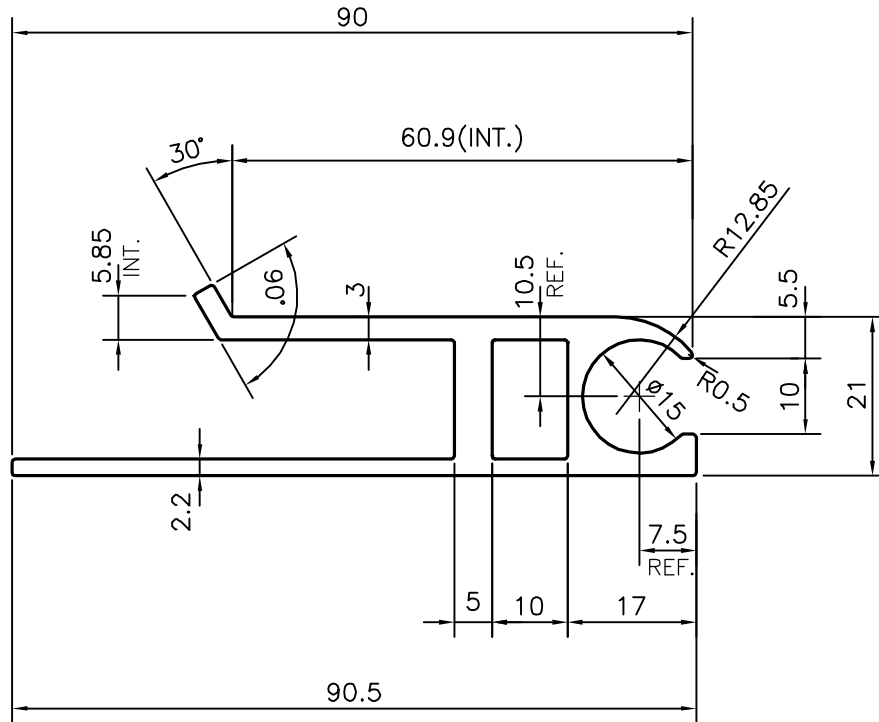

SYMBOL OF QUALITY
AN ISO 9001 COMPANY

JINDAL ALUMINIUM LTD.
BANGALORE-560073 (INDIA)

	NAME	DATE
DRAWN	J.P.KAUSHIK	31-05-2016
CHECKED		
APPROVED	S.S. GARG	02-06-2016

1. ALL DIMENSIONS ARE IN mm.
2. ROUND OFF ALL SHARP CORNERS WITH 0.40 mm.
3. TOLERANCES WILL BE AS PER, IS:6477-1983 UNLESS OTHERWISE SPECIFIED

SCALE	1:1
AREA mm ²	550.948
PERIMETER mm.	319.236
WEIGHT kg/m	1.488

PARTY'S NAME P.D. PROJECTS, NEW DELHI

DRAWING No. SECTION No.

PARTY'S DRAWING No. AS PER DRAWING

P-15913 -
S4959 S4959
17750 17750

ALLOY & TEMPER HE9 WP

DESCRIPTION FLOOR SECTION