

P-18016
X2315
17780

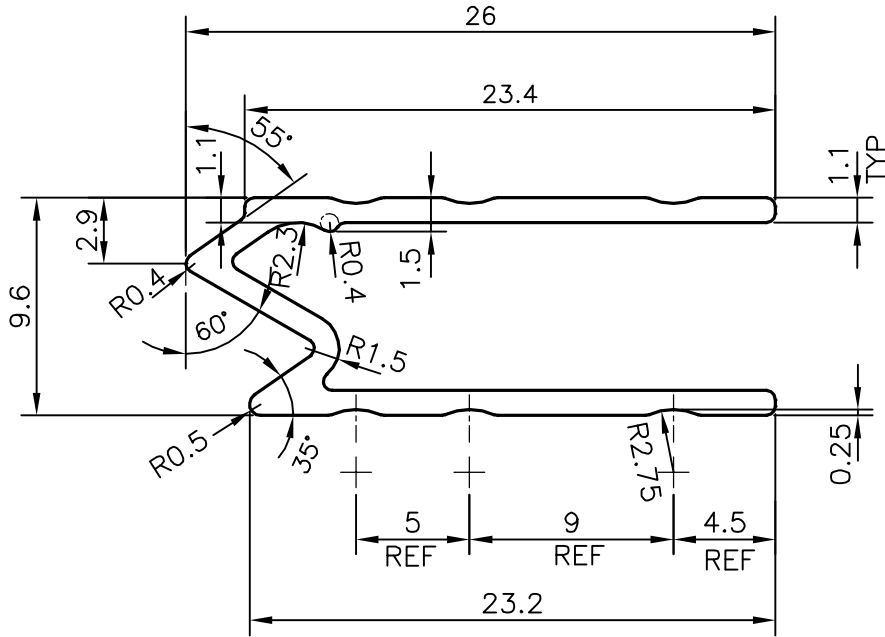
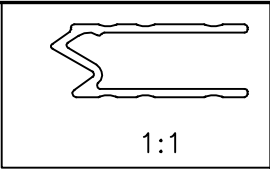

JINDAL ALUMINIUM LTD.
BANGALORE-560073 (INDIA)

	NAME	DATE
DRAWN	J.P.KAUSHIK	20-03-2018
CHECKED		
APPROVED	B.NATARAJA	27-03-2018

1. ALL DIMENSIONS ARE IN mm.
2. ROUND OFF ALL SHARP CORNERS WITH 0.40 mm.
3. TOLERANCES WILL BE AS PER IS:3965-1981 , UNLESS OTHERWISE SPECIFIED

SCALE	3:1
AREA mm ²	63.412
PERIMETER mm.	116.577
WEIGHT kg/m	0.171

PARTY'S NAME	PREMIER METAL, NEW DELHI
PARTY'S DRAWING No.	MODIFIED OF 17553
ALLOY & TEMPER	6063 T6
DESCRIPTION	MISC. CHANNEL

DRAWING No.	SECTION No.
P-18016	-
X2315	X2315
17780	17780