

P-22814

17794

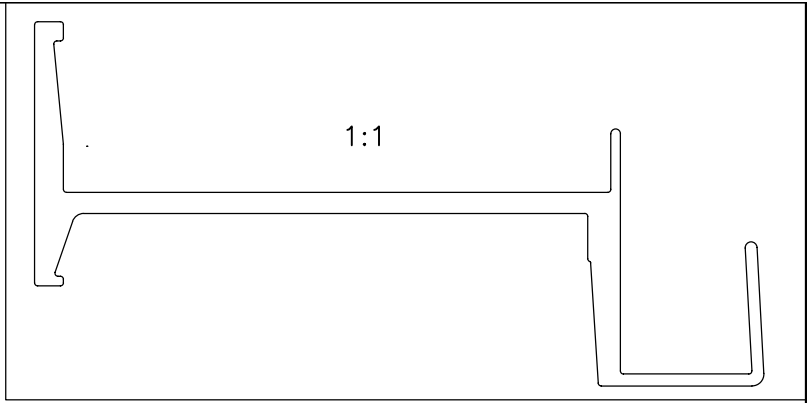

1:1

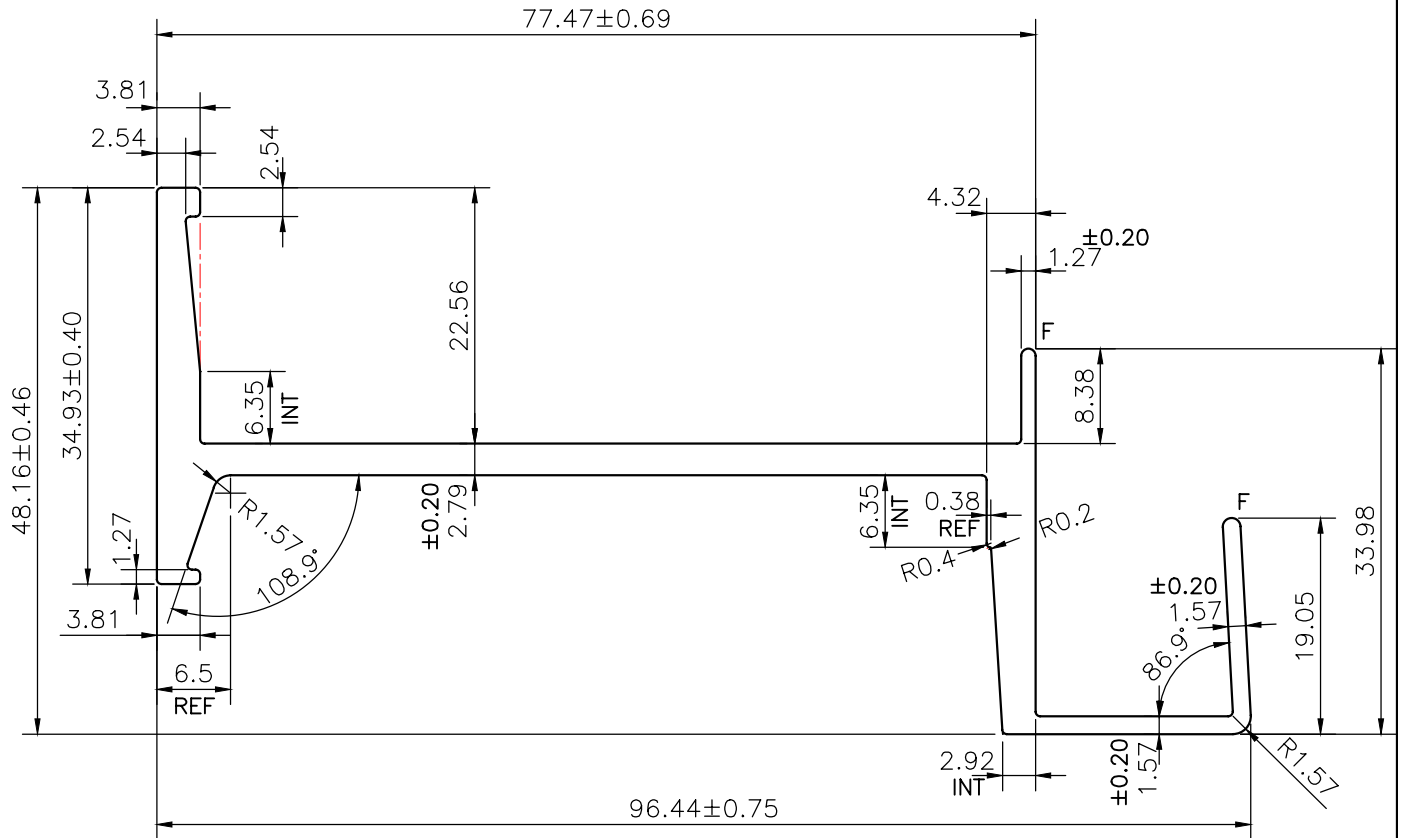

APPROXIMATE WEIGHT RANGE -1.171 - 1.431 kg/m

F = FULL RADIUS (2 PLACES)

 SYMBOL OF QUALITY AN ISO 9001 COMPANY	JINDAL ALUMINIUM LTD. BANGALORE-560073 (INDIA)	DRAWN	NAME	DATE
		CHECKED	J.P.KAUSHIK	24-07-2021
1. ALL DIMENSIONS ARE IN mm. 2. ROUND OFF ALL SHARP CORNERS WITH 0.40 mm. 3. TOLERANCES WILL BE AS PER IS:3965-1981 , UNLESS OTHERWISE SPECIFIED		APPROVED	B.NATARAJA	16-08-2021
		SCALE		1.5:1
PARTY'S NAME VIJAY ENGINEERING WORKS, JALANDHAR		AREA mm ²		481.95
		PERIMETER mm.		355.662
PARTY'S DRAWING No. AS PER DRAWING		WEIGHT kg/m		1.301
		DRAWING No.		
ALLOY & TEMPER 6061 T6			SECTION No.	
		P-22814		-
DESCRIPTION SCAFFOLDING SECTION		17794		17794