

4955

18019

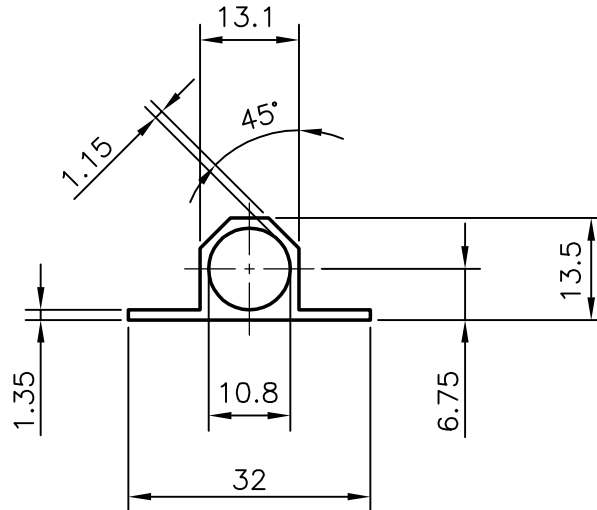

3658 mm. LONG PIECES IN 100 kgs.:– 107



SYMBOL OF QUALITY  
AN ISO 9002 COMPANY

**JINDAL ALUMINIUM LTD.**  
BANGALORE-560073 (INDIA)

	NAME	DATE
DRAWN	R.D.Sharma	03-01-03
CHECKED		
APPROVED		
SCALE	1:1	
AREA mm <sup>2</sup>	94.5	
PERIMETER mm.	86.3	
WEIGHT kg/m	0.255	
SECTION No.	18019	
DRAWING No.	18019	

1. ALL DIMENSIONS ARE IN mm.
2. ROUND OFF ALL SHARP CORNERS WITH 0.40 mm.
3. TOLERANCES WILL BE AS PER IS 6477-1983 UNLESS OTHERWISE SPECIFIED

PARTY'S NAME ALUMINIUM & ALUMINIUM, DELHI

PARTY'S DRAWING No. NIL

ALLOY & TEMPER HE9 WP

DESCRIPTION TOWER BOLT