

4964

18027

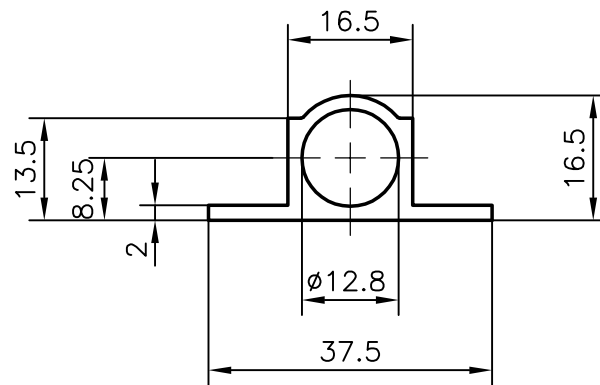

JINDAL ALUMINIUM LTD.

BANGALORE-560073

		NAME	DATE
		DRAWN	R.D.Sharma
1. ALL DIMENSIONS ARE IN mm. 2. ROUND OFF ALL SHARP CORNERS WITH 0.4 mm. 3. TOLERANCES WILL BE AS PER IS: 6477-1983 ,UNLESS OTHERWISE SPECIFIED		CHECKED	
		APPROVED	
PARTY'S NAME	—	SCALE	1:1
PARTY'S DRAWING No.	NIL	WEIGHT kg/m	0.439
ALLOY & TEMPER	HE9 WP	SECTION No.	18027
LENGTH	—	DRAWING No.	
DESCRIPTION	TOWER BOLT	18027	