

4974

18037

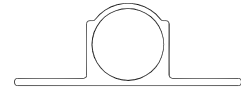

1:1

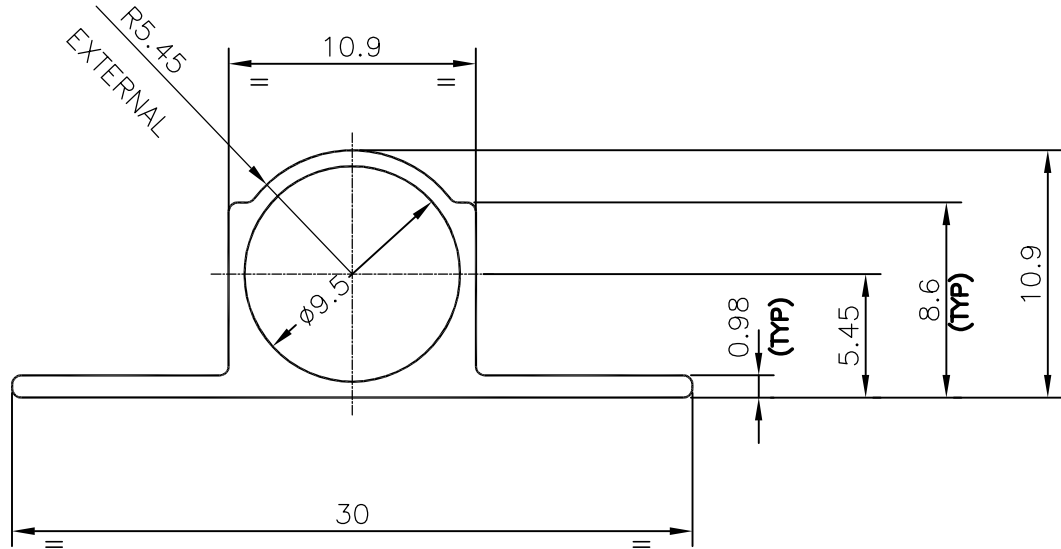

WEIGHT PER PIECE = 0.550 kg (AVARAGE)

JINDAL ALUMINIUM LTD.
BANGALORE-560073

NAME

DATE

DRAWN

P,KULKARNI

1-6-99

1. ALL DIMENSIONS ARE IN mm.
2. ROUND OFF ALL SHARP CORNERS WITH 0.4 mm.
3. TOLERANCES WILL BE AS PER IS: 6477-1983 UNLESS OTHERWISE SPECIFIED

CHECKED

APPROVED

PARTY'S NAME

GENERAL CATEGORY (DELHI MARKET)

SCALE

3:1

PARTY'S DRAWING No.

4969 (JINDAL) MODIFIED

WEIGHT kg/m

0.150

ALLOY & TEMPER

HE9 WP

SECTION No.

18037

LENGTH

3658 mm.

DRAWING No.

DESCRIPTION

TOWER BOLT

18037