

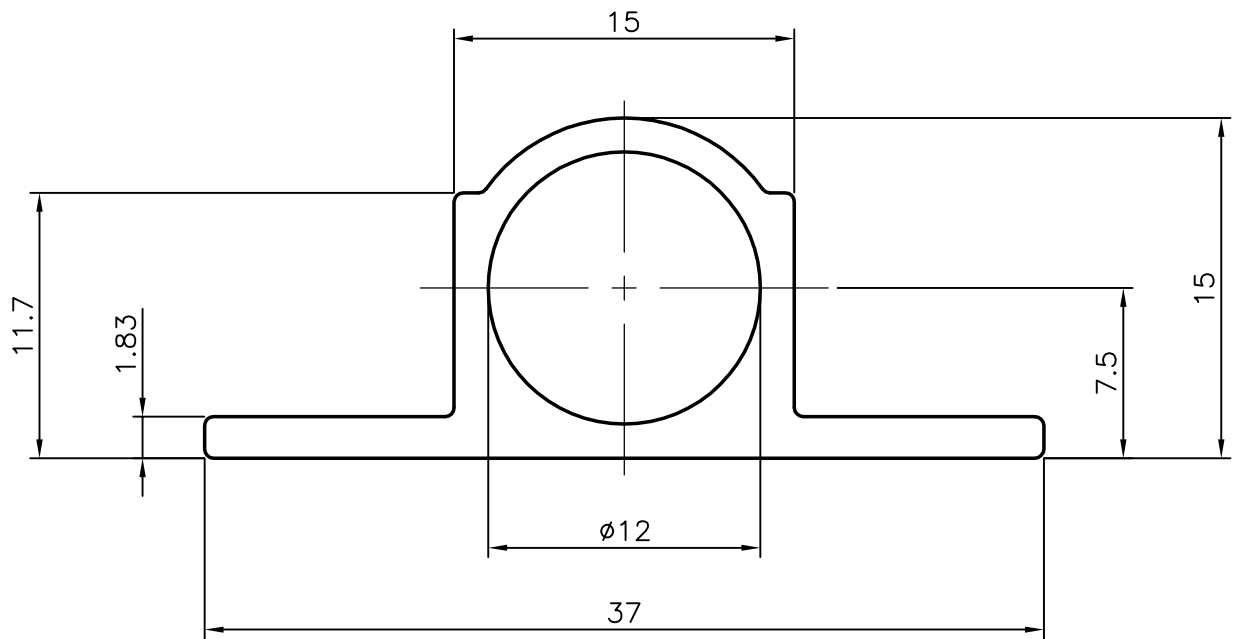

4977
18040
-

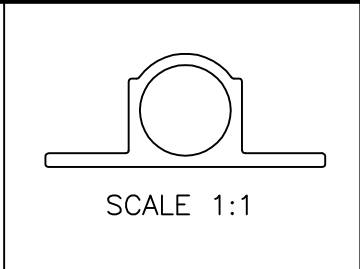

NO OF PIECES IN 100 kgs:- 77 (AVERAGE)

 SYMBOL OF QUALITY AN ISO 9001 COMPANY	JINDAL ALUMINIUM LTD. BANGALORE-560073 (INDIA)	DRAWN	NAME	DATE
		CHECKED	PRASANN.H	09-02-2007
1. ALL DIMENSIONS ARE IN mm. 2. ROUND OFF ALL SHARP CORNERS WITH 0.4 mm. 3. TOLERANCES WILL BE AS PER IS:6477-1983 UNLESS OTHERWISE SPECIFIED		APPROVED		
		SCALE		3:1
PARTY'S NAME GENERAL CATEGORY., DELHI MARKET		AREA mm ²		131.364
		PERIMETER mm.		98.18
PARTY'S DRAWING No. LIGHTER SECTION OF 4966		WEIGHT kg/m		0.354
		DRAWING No.	SECTION No.	
ALLOY & TEMPER HE9 WP		4977	4977	
		18040	18040	
DESCRIPTION TOWER BOLT		-	-	