

4978

18041

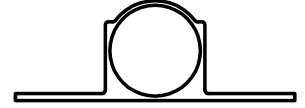

SCALE 1:1

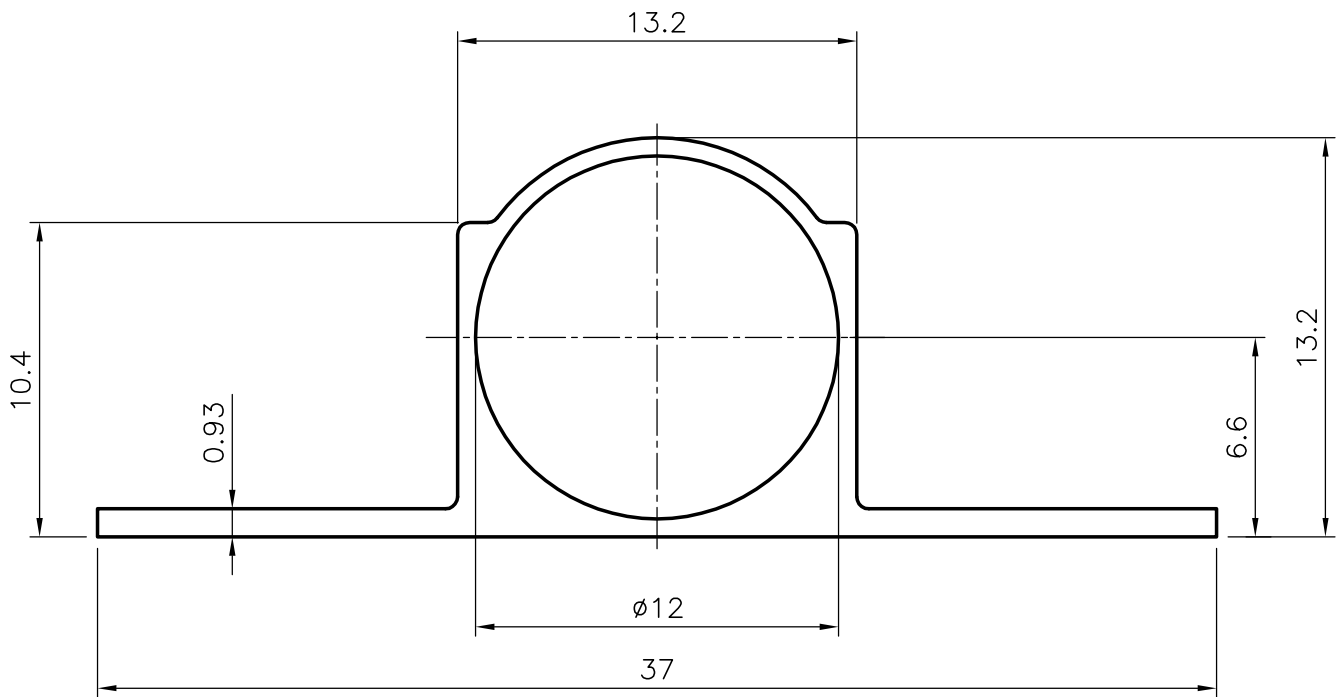

NO OF PIECES IN 100 kgs:- 150 (AVERAGE)



SYMBOL OF QUALITY
AN ISO 9002 COMPANY

JINDAL ALUMINIUM LTD.
BANGALORE-560073 (INDIA)

	NAME	DATE
DRAWN	RAGHAVENDRA	10-10-01
CHECKED		
APPROVED		
SCALE	4:1 & 1:1	
WEIGHT kg/m	0.182	
PERIMETER	95.89mm	
SECTION No.	18041	
DRAWING No.	18041	

1. ALL DIMENSIONS ARE IN mm.
2. ROUND OFF ALL SHARP CORNERS WITH 0.40 mm.
3. TOLERANCES WILL BE AS PER I.S 6477-1983 UNLESS OTHERWISE SPECIFIED

PARTY'S NAME	GENERAL CATEGORY ,. DELHI MARKET
PARTY'S DRAWING No.	LIGHTER SECTION OF 4967
ALLOY & TEMPER	HE9 WP
DESCRIPTION	TOWER BOLT