

4979
18042
-

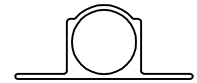

SCALE 1:1

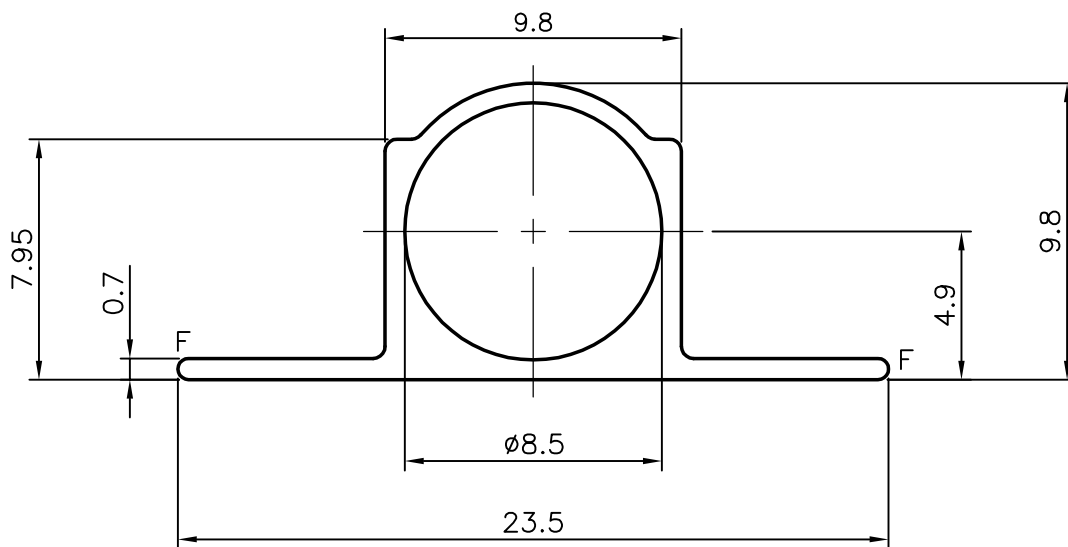

NOTE:-

1. NO OF PIECES IN 100 kgs:- 250 (AVERAGE)
2. F = FULL RADIUS (2 PLACES)

 SYMBOL OF QUALITY AN ISO 9001 COMPANY	JINDAL ALUMINIUM LTD. BANGALORE-560073 (INDIA)	DRAWN	NAME	DATE
		CHECKED	PRASANN.H	09-02-2007
1. ALL DIMENSIONS ARE IN mm. 2. ROUND OFF ALL SHARP CORNERS WITH 0.4 mm. 3. TOLERANCES WILL BE AS PERIS:6477-1983 UNLESS OTHERWISE SPECIFIED		APPROVED		
		SCALE		4:1
PARTY'S NAME GENERAL CATEGORY., DELHI MARKET		AREA mm ²		40.546
		PERIMETER mm.		62.703
PARTY'S DRAWING No. LIGHTER SECTION OF 4970		WEIGHT kg/m		0.109
		DRAWING No.	SECTION No.	
ALLOY & TEMPER HE9 WP		4979		4979
		18042		18042
DESCRIPTION TOWER BOLT		-		-