

4982

18045

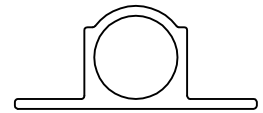

SCALE 1:1

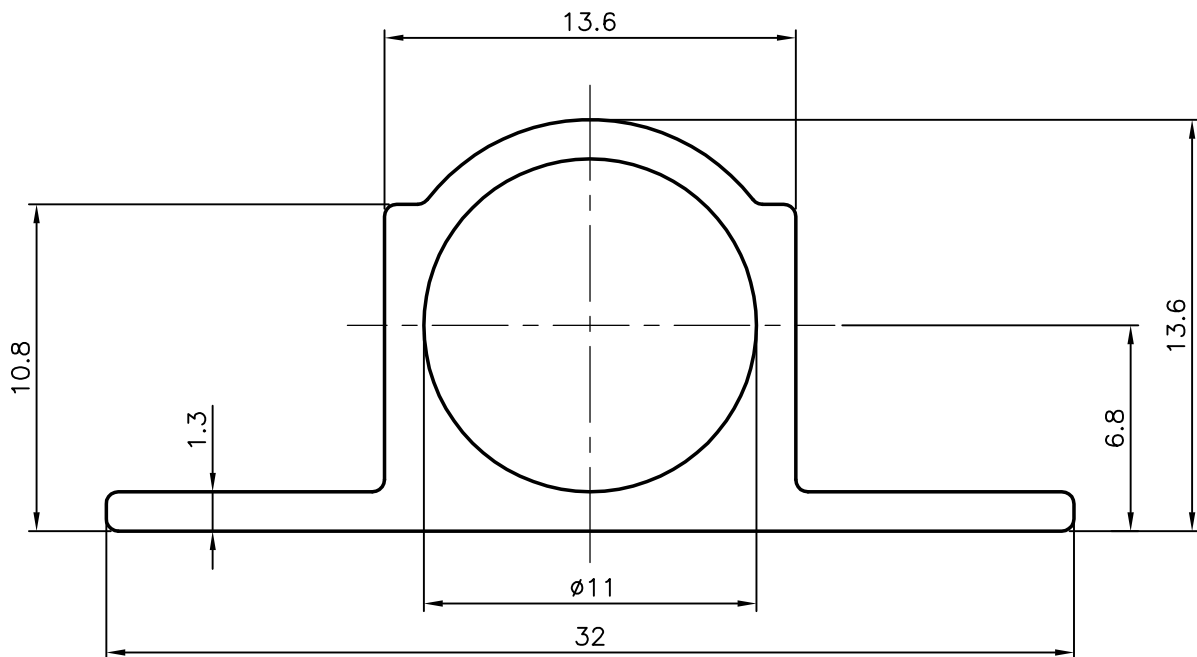

3658mm LONG PIECES IN 100 kgs:-104 (AVERAGE)



SYMBOL OF QUALITY
AN ISO 9001 COMPANY

JINDAL ALUMINIUM LTD.
BANGALORE-560073 (INDIA)

	NAME	DATE
DRAWN	RAGHAVENDRA	24-10-2006
CHECKED		
APPROVED		

1. ALL DIMENSIONS ARE IN mm.
2. ROUND OFF ALL SHARP CORNERS WITH 0.40 mm.
3. TOLERANCES WILL BE AS PER IS:6477-1983 UNLESS OTHERWISE SPECIFIED

SCALE	4:1
AREA mm ²	97.199
PERIMETER mm.	85.98
WEIGHT kg/m	0.262

PARTY'S NAME	-	DRAWING No.	4982	SECTION No.	-
PARTY'S DRAWING No.	LIGHTER OF 4003	18045	18045		
ALLOY & TEMPER	HE9 WP				
DESCRIPTION	TOWER BOLT				