

P-4207

4989

18052

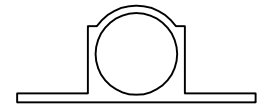

1:1

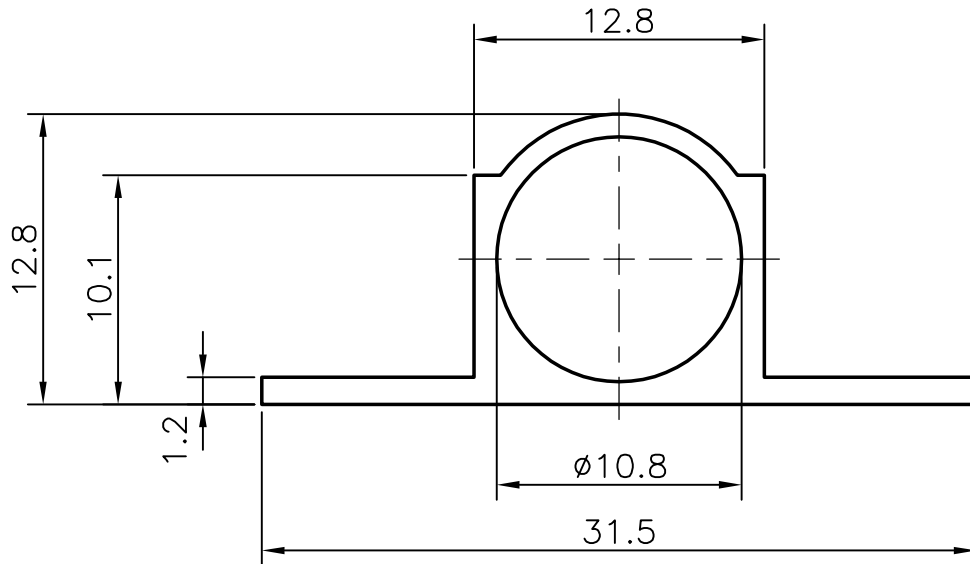

WEIGHT PER 3658 mm. (12'):- 0.790 kg (AVERAGE)



SYMBOL OF QUALITY
AN ISO 9002 COMPANY

JINDAL ALUMINIUM LTD.
BANGALORE-560073 (INDIA)

	NAME	DATE
DRAWN	R.D.Sharma	26-04-03
CHECKED		
APPROVED		
SCALE	3:1	
AREA mm ²	79.9	
PERIMETER mm.	85	
WEIGHT kg/m	0.216	
SECTION No.	18052	
DRAWING No.	18052	

1. ALL DIMENSIONS ARE IN mm.
2. ROUND OFF ALL SHARP CORNERS WITH 0.40 mm.
3. TOLERANCES WILL BE AS PER IS 6477-1983 UNLESS OTHERWISE SPECIFIED

PARTY'S NAME	GENERAL CATEGORY, DELHI MARKET
PARTY'S DRAWING No.	AS PER SAMPLE
ALLOY & TEMPER	HE9 WP
DESCRIPTION	TOWER BOLT