

P-5322

18055

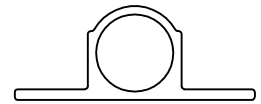

1:1

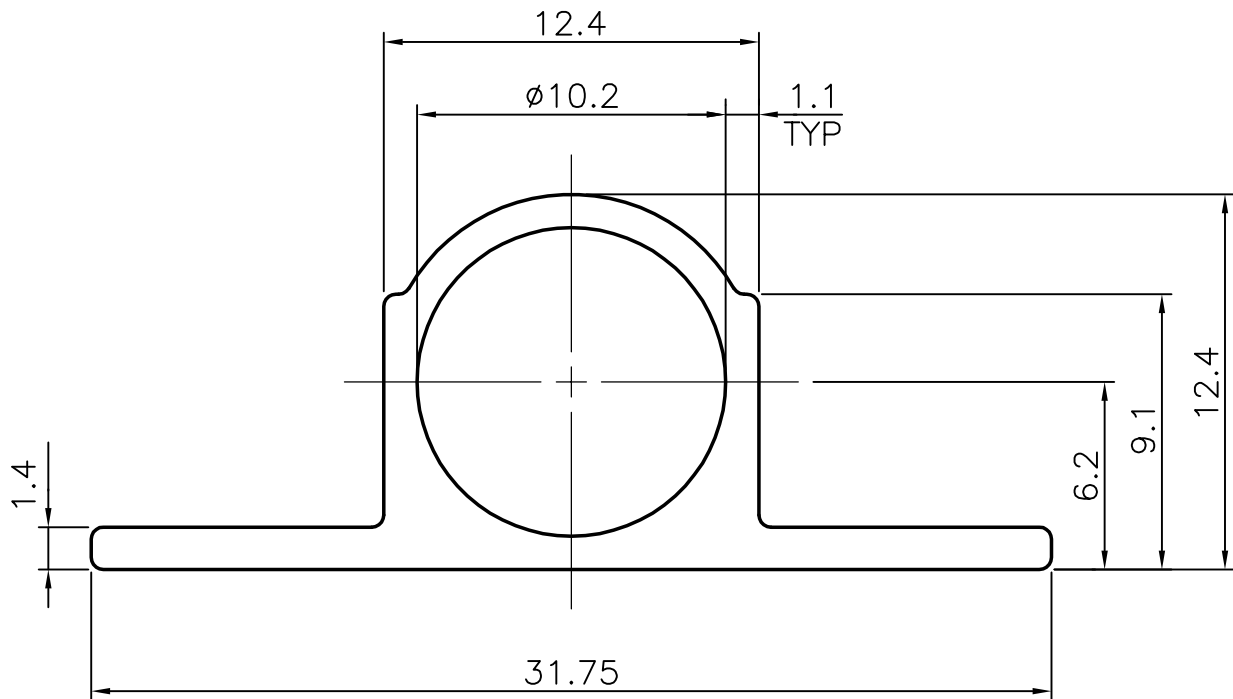

AVERAGE WEIGHT:- 0.826 kg/ 3658 mm.



SYMBOL OF QUALITY
AN ISO 9002 COMPANY

JINDAL ALUMINIUM LTD.
BANGALORE-560073 (INDIA)

	NAME	DATE
DRAWN	MALINGAPPA	25.02.2005
CHECKED		
APPROVED		
SCALE		1:1
AREA mm ²		83.877
PERIMETER mm.		82.718
WEIGHT kg/m		0.226
DRAWING No.	SECTION No.	
P-5322	-	
18055	18055	

1. ALL DIMENSIONS ARE IN mm.
2. ROUND OFF ALL SHARP CORNERS WITH 0.40 mm.
3. TOLERANCES WILL BE AS PER IS: 6477-1983 UNLESS OTHERWISE SPECIFIED

PARTY'S NAME	GENERAL CATEGORY, DELHI MARKET
PARTY'S DRAWING No.	LIGHTER OF SECTION NO. 18015
ALLOY & TEMPER	HE9 WP
DESCRIPTION	TOWER BOLT