

P-5329

18057

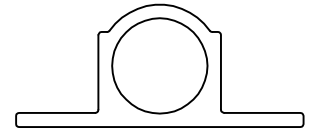

1:1

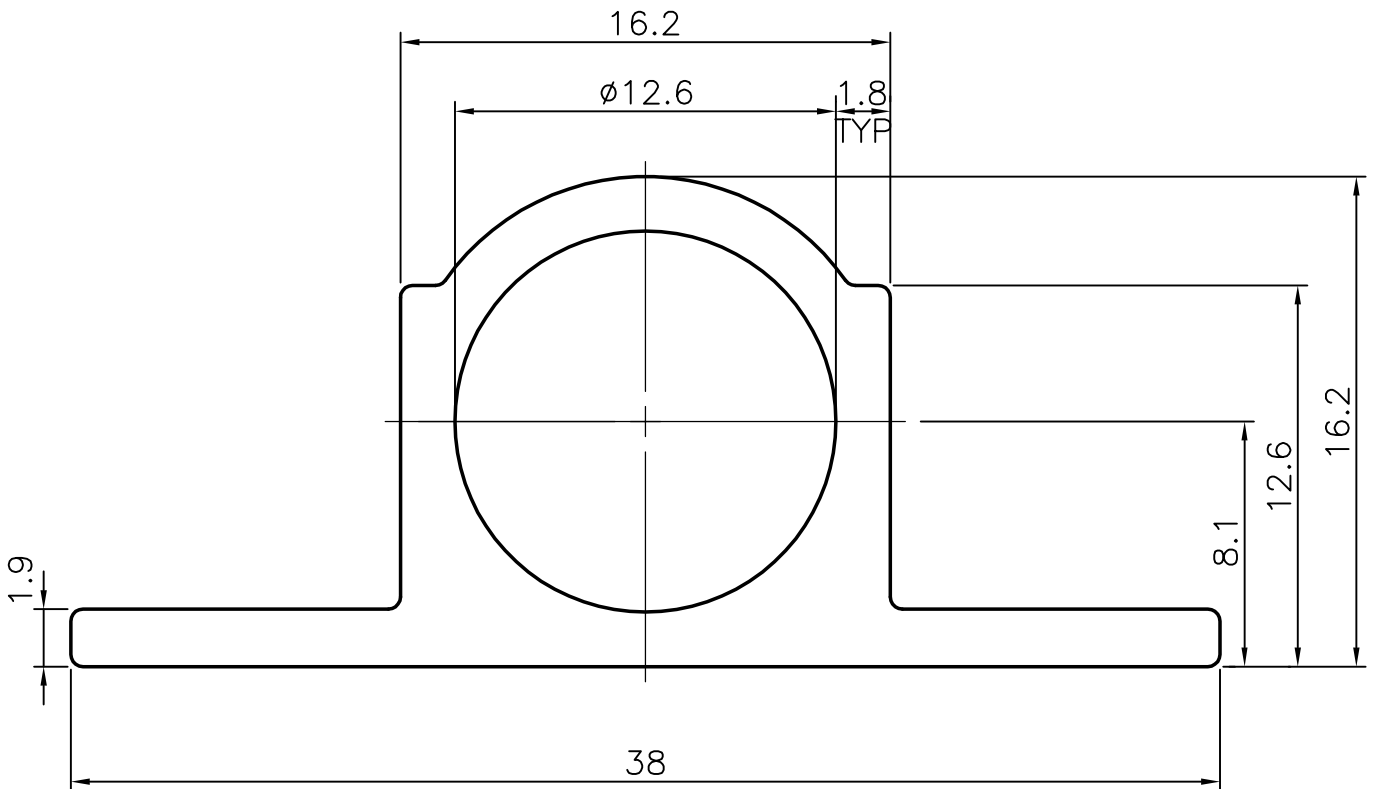

AVERAGE WEIGHT:- 1.529 kg/ 3658 mm.



SYMBOL OF QUALITY  
AN ISO 9002 COMPANY

**JINDAL ALUMINIUM LTD.**  
BANGALORE-560073 (INDIA)

	NAME	DATE
DRAWN	MALINGAPPA	24.02.2005
CHECKED		
APPROVED		
SCALE		1:1
AREA mm <sup>2</sup>		154.832
PERIMETER mm.		102.194
WEIGHT kg/m		0.418
DRAWING No.	SECTION No.	
P-5329	-	
18057	18057	

1. ALL DIMENSIONS ARE IN mm.
2. ROUND OFF ALL SHARP CORNERS WITH 0.40 mm.
3. TOLERANCES WILL BE AS PER IS: 6477-1983 UNLESS OTHERWISE SPECIFIED

PARTY'S NAME	GENERAL CATEGORY, DELHI MARKET
PARTY'S DRAWING No.	LIGHTER OF SECTION NO. 18016
ALLOY & TEMPER	HE9 WP
DESCRIPTION	TOWER BOLT