

P-5340

18060

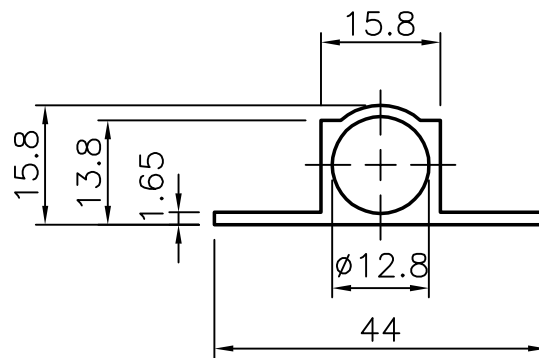

WEIGHT PER 3658 mm. LONG PIECE:- 1.485 kg.



SYMBOL OF QUALITY
AN ISO 9002 COMPANY

JINDAL ALUMINIUM LTD.
BANGALORE-560073 (INDIA)

	NAME	DATE
DRAWN	MALINGAPPA	25.02.2005
CHECKED		
APPROVED		
SCALE	3:1	
AREA mm ²	150.3	
PERIMETER mm.	116.59	
WEIGHT kg/m	0.406	
DRAWING No.	SECTION No.	
P-5340	-	
18060	18060	

1. ALL DIMENSIONS ARE IN mm.
2. ROUND OFF ALL SHARP CORNERS WITH 0.40 mm.
3. TOLERANCES WILL BE AS PER IS: 6477-1983 UNLESS OTHERWISE SPECIFIED

PARTY'S NAME	GENERAL CATEGORY, DELHI MARKET
PARTY'S DRAWING No.	AS PER SPECIFICATION (18038)
ALLOY & TEMPER	HE9 WP
DESCRIPTION	TOWER BOLT