

P-8773

18062

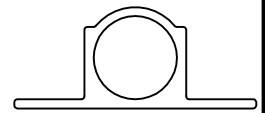

SCALE 1:1

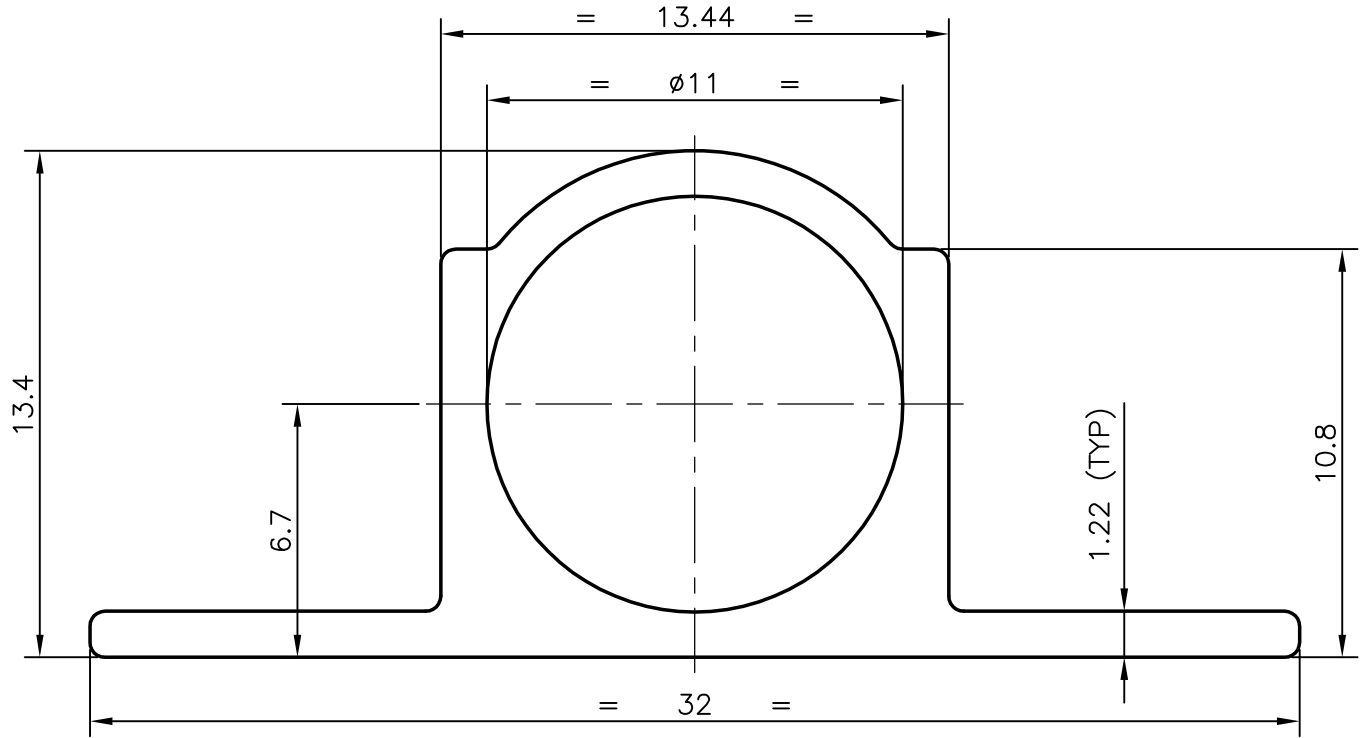

NO. OF PIECE IN 100kgs:- 110 (AVERAGE)



SYMBOL OF QUALITY
AN ISO 9001 COMPANY

JINDAL ALUMINIUM LTD.
BANGALORE-560073 (INDIA)

	NAME	DATE
DRAWN	PRASANNA.H	06-11-2008
CHECKED		
APPROVED		

1. ALL DIMENSIONS ARE IN mm.
2. ROUND OFF ALL SHARP CORNERS WITH 0.4 mm.
3. TOLERANCES WILL BE AS PER IS:6477-1983 UNLESS OTHERWISE SPECIFIED

SCALE	5:1
AREA mm ²	91.861
PERIMETER mm.	85.801
WEIGHT kg/m	0.248

PARTY'S NAME	GENERAL CATEGORY, DELHI MARKET
PARTY'S DRAWING No.	LIGHTER OF 18045
ALLOY & TEMPER	HE9 WP
DESCRIPTION	TOWER BOLT SECTION

DRAWING No.	SECTION No.
P-8773	-
18062	18062