

P-16109

18070

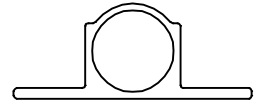

1:1

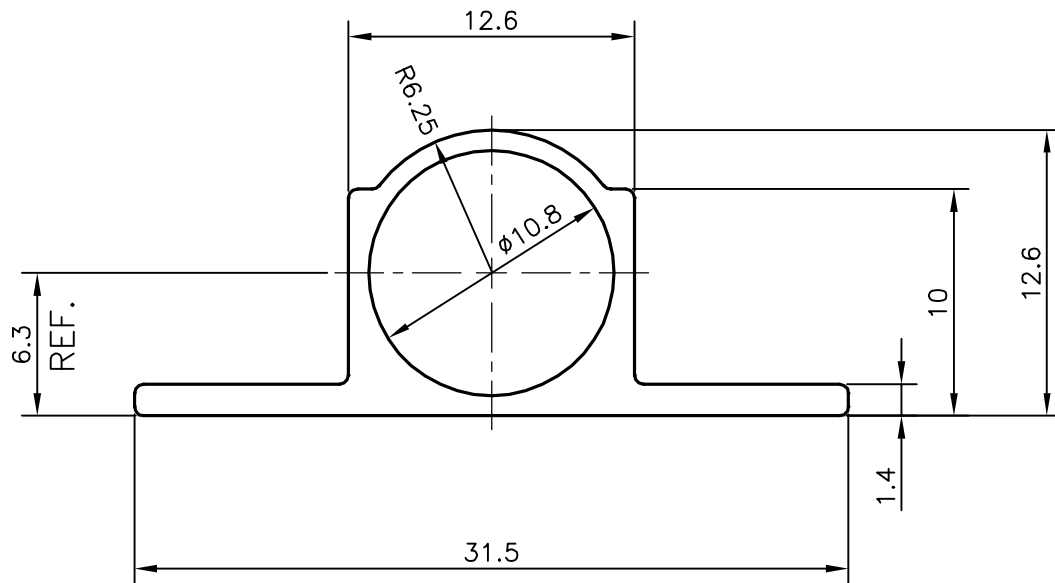

3658 mm LONG PIECES IN 100 kgs 127 PIECES (AVERAGE)



SYMBOL OF QUALITY  
AN ISO 9001 COMPANY

**JINDAL ALUMINIUM LTD.**  
BANGALORE-560073 (INDIA)

	NAME	DATE
DRAWN	J.P.KAUSHIK	16-07-2016
CHECKED		
APPROVED	S.S. GARG	09-08-2016

1. ALL DIMENSIONS ARE IN mm.
2. ROUND OFF ALL SHARP CORNERS WITH 0.40 mm.
3. TOLERANCES WILL BE AS PER IS:6477-1983 UNLESS OTHERWISE SPECIFIED

SCALE	3:1
AREA mm <sup>2</sup>	79.205
PERIMETER mm.	83.26
WEIGHT kg/m	0.214

PARTY'S NAME	GENERAL CATEGORY, DELHI MARKET	DRAWING No.	P-16109	SECTION No.	-
PARTY'S DRAWING No.	AS PER DRAWING		18070		18070
ALLOY & TEMPER	HE9 WP				
DESCRIPTION	TOWER BOLT SECTION				