

P-16110-1

18071

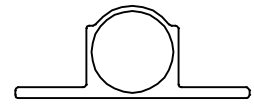

1:1

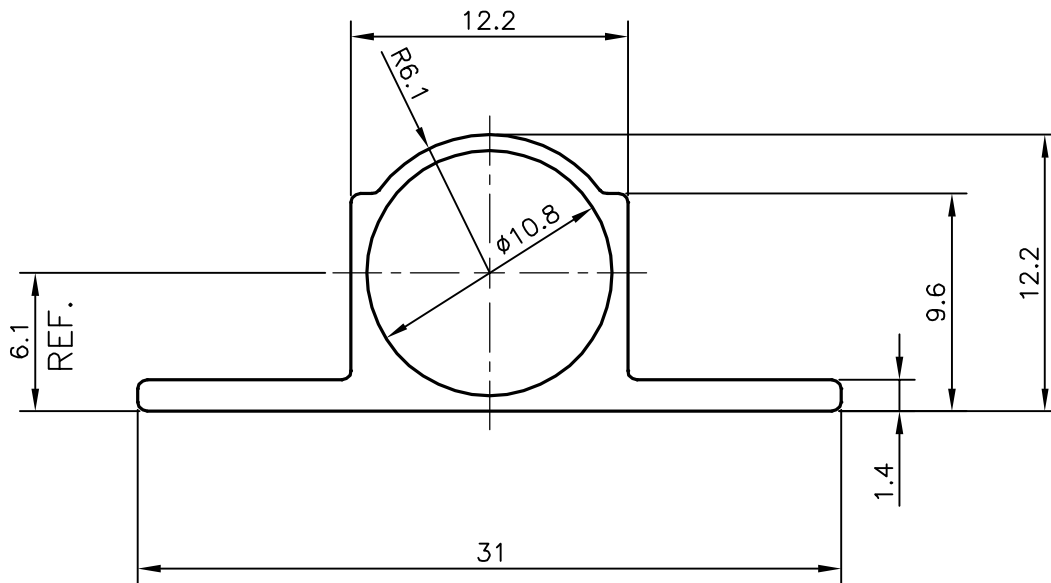

3658 mm LONG PIECES IN 100 kgs 145 PIECES (AVERAGE)



SYMBOL OF QUALITY
AN ISO 9001 COMPANY

JINDAL ALUMINIUM LTD.
BANGALORE-560073 (INDIA)

	NAME	DATE
DRAWN	J.P.KAUSHIK	20-07-2016
CHECKED		
APPROVED	S.S. GARG	09-08-2016
SCALE		3:1
AREA mm ²		69.93
PERIMETER mm.		81.481
WEIGHT kg/m		0.189
DRAWING No.	SECTION No.	
P-16110-1	-	
18071	18071	

1. ALL DIMENSIONS ARE IN mm.
2. ROUND OFF ALL SHARP CORNERS WITH 0.40 mm.
3. TOLERANCES WILL BE AS PER IS:6477-1983 UNLESS OTHERWISE SPECIFIED

PARTY'S NAME	GENERAL CATEGORY, DELHI MARKET
PARTY'S DRAWING No.	AS PER DRAWING
ALLOY & TEMPER	HE9 WP
DESCRIPTION	TOWER BOLT SECTION