

P-21084

18096

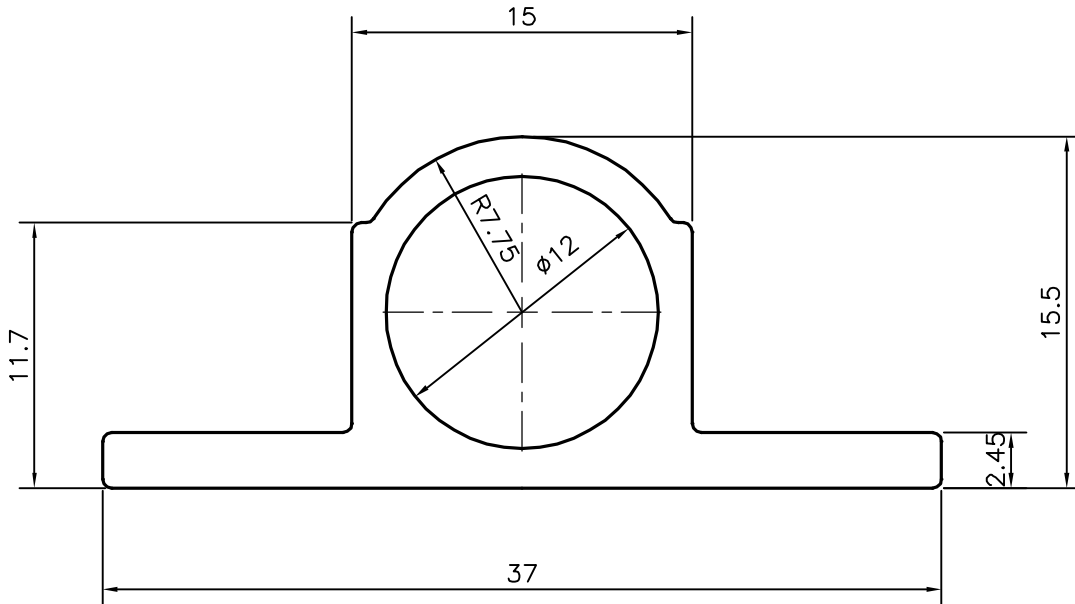

WEIGHT SHOULD BE 1.440 TO 1.550 kg/3658 mm LENGTH.

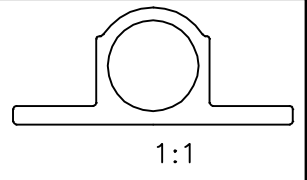

SYMBOL OF QUALITY
AN ISO 9001 COMPANY

JINDAL ALUMINIUM LTD.
BANGALORE-560073 (INDIA)

	NAME	DATE
DRAWN	J.P.KAUSHIK	10-06-2020
CHECKED		
APPROVED	B.NATARAJA	18-06-2020
SCALE		3:1
AREA mm ²		152.067
PERIMETER mm.		98.669
WEIGHT kg/m		0.411
DRAWING No.	SECTION No.	
P-21084		
18096	18096	

1. ALL DIMENSIONS ARE IN mm.
2. ROUND OFF ALL SHARP CORNERS WITH 0.40 mm.
3. TOLERANCES WILL BE AS PER IS:6477-1983 UNLESS OTHERWISE SPECIFIED

PARTY'S NAME ATCO ALUMINIUM SYSTEMS, DELHI

PARTY'S DRAWING No. HEAVIER OF 18029

ALLOY & TEMPER HE9 WP A3D

DESCRIPTION TOWER BOLT