

P-21141

18097

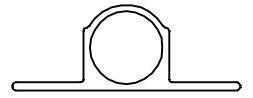

1:1

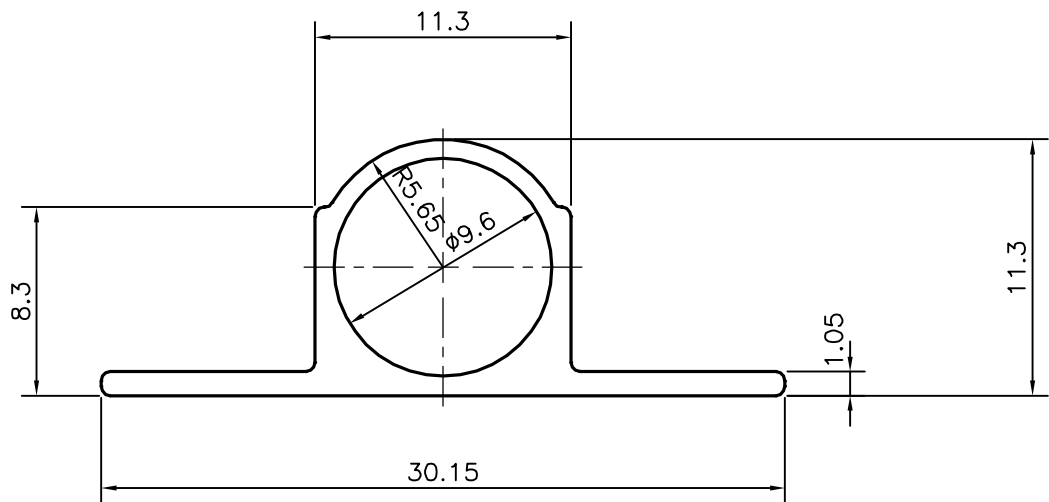

SYMBOL OF QUALITY
AN ISO 9001 COMPANY

JINDAL ALUMINIUM LTD.
BANGALORE-560073 (INDIA)

	NAME	DATE
DRAWN	J.P.KAUSHIK	23-06-2020
CHECKED		
APPROVED	B.NATARAJA	02-07-2020
SCALE		3:1
AREA mm ²		62.417
PERIMETER mm.		77.69
WEIGHT kg/m		0.169
DRAWING No.	SECTION No.	
P-21141		
18097	18097	

1. ALL DIMENSIONS ARE IN mm.
2. ROUND OFF ALL SHARP CORNERS WITH 0.40 mm.
3. TOLERANCES WILL BE AS PER IS:6477-1983 UNLESS OTHERWISE SPECIFIED

PARTY'S NAME ATCO ALUMINIUM SYSTEMS, DELHI

PARTY'S DRAWING No. LIGHTER OF 18084

ALLOY & TEMPER HE9 WP A3D

DESCRIPTION TOWER BOLT