

P-21467

18099

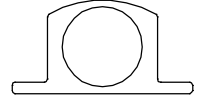

SCALE: - 1:1

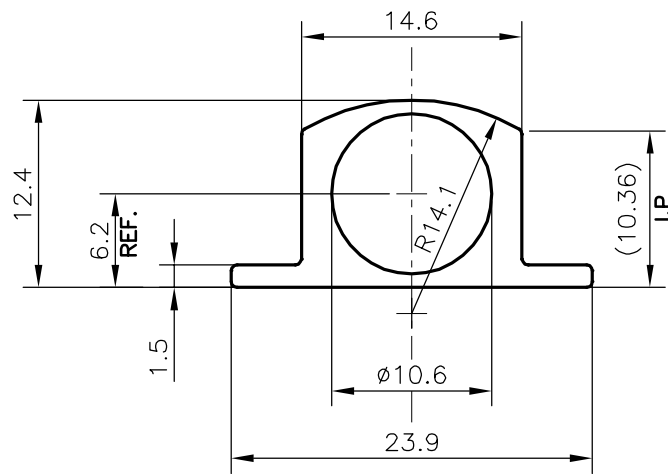

SCALE: - 2:1

WEIGHT RANGE (kg/m) - 0.236 - 0.288 (APPROX.)

TOLERANCES ON OVERALL DIMENSIONS OF HOLLOW SECTIONS

UPTO 20.0mm - ± 0.30
 UPTO 30.0mm - ± 0.38
 UPTO 40.0mm - ± 0.45
 UPTO 50.0mm - ± 0.52
 UPTO 60.0mm - ± 0.60

UPTO 80.0mm - ± 0.70
 UPTO 100.0mm - ± 0.80
 UPTO 120.0mm - ± 0.90
 UPTO 140.0mm - ± 1.00
 UPTO 160.0mm - ± 1.14

UPTO 180.0mm - ± 1.27
 UPTO 200.0mm - ± 1.40
 UPTO 225.0mm - ± 1.52

1. STRAIGHTNESS=1.7mm/M
 2. TWIST=1.7mm/M
 3. ANGULARITY= $\pm 2^\circ$
 4. FLATNESS =0.006xWIDTH



SYMBOL OF QUALITY
 AN ISO 9001 COMPANY

JINDAL ALUMINIUM LTD.
 BANGALORE-560073 (INDIA)

	NAME	DATE
DRAWN	DARPAN	14-09-2020
CHECKED		
APPROVED	B.NATARAJA	19/09/2020

SCALE	2:1
AREA mm ²	97.05
PERIMETER mm.	68.16
WEIGHT kg/m	0.262
DRAWING No.	SECTION No.
P-21467	-
18099	18099

- ALL DIMENSIONS ARE IN mm.
- ROUND OFF ALL SHARP CORNERS WITH 0.40 mm.
- TOLERANCES WILL BE AS PER **IS:6477-1983**, UNLESS OTHERWISE SPECIFIED

PARTY'S NAME	ALUMINIUM TRADING COMPANY, DELHI
PARTY'S DRAWING No.	MODIFIED SECTION OF 18078
ALLOY & TEMPER	HE9 WP A3D
DESCRIPTION	TOWER BOLT SECTION