

P-21799

18100

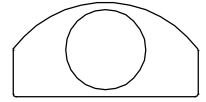

SCALE:- 1:1

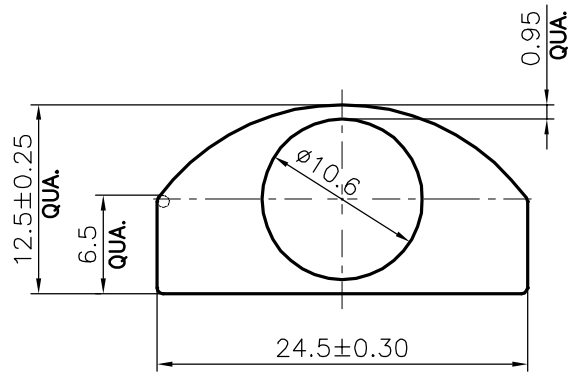

SCALE:- 2:1

**WEIGHT RANGE (kg/m) – 0.418 – 0.510 (APPROX.)**



SYMBOL OF QUALITY  
AN ISO 9001 COMPANY

**JINDAL ALUMINIUM LTD.**  
BANGALORE-560073 (INDIA)

	NAME	DATE
DRAWN	DARPAN	23-11-2020
CHECKED		
APPROVED	B.NATARAJA	02-12-2020

1. ALL DIMENSIONS ARE IN mm.
2. ROUND OFF ALL SHARP CORNERS WITH 0.40 mm.
3. TOLERANCES WILL BE AS PER **IS:6477-1983** UNLESS OTHERWISE SPECIFIED

SCALE	<b>2:1</b>
AREA mm <sup>2</sup>	<b>171.907</b>
PERIMETER mm.	<b>65.176</b>
WEIGHT kg/m	<b>0.464</b>

PARTY'S NAME ALUMINIUM TRADING COMPANY, NEW DELHI

DRAWING No. SECTION No.

PARTY'S DRAWING No. MODIFIED OF 18080

**P-21799**

ALLOY & TEMPER HE9 WP A3D

18100

18100

DESCRIPTION

TOWER BOLT