

P-21861

18102

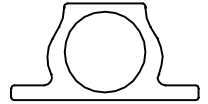

1:1

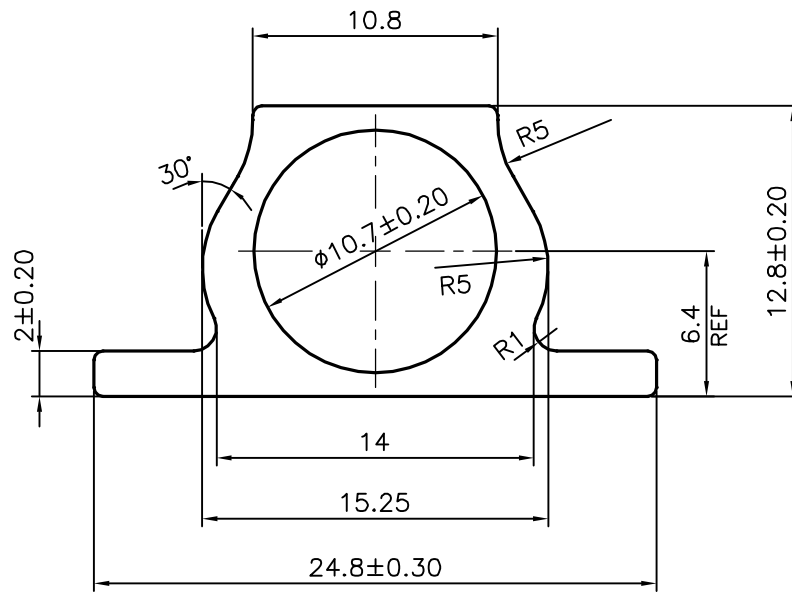

APPROXIMATE WEIGHT RANGE - 0.254 - 0.311 kg/m



SYMBOL OF QUALITY
AN ISO 9001 COMPANY

JINDAL ALUMINIUM LTD.
BANGALORE-560073 (INDIA)

1. ALL DIMENSIONS ARE IN mm.
2. ROUND OFF ALL SHARP CORNERS WITH 0.40 mm.
3. TOLERANCES WILL BE AS PER IS:6477-1983 UNLESS OTHERWISE SPECIFIED

		NAME	DATE
PARTY'S NAME	ALUMINIUM TRADING COMPANY, NEW DELHI	DRAWN J.P.KAUSHIK	14-12-2020
PARTY'S DRAWING No.	MODIFIED OF 18077	CHECKED	
ALLOY & TEMPER	HE9 WP A3D	APPROVED B.NATARAJA	17-12-2020
DESCRIPTION	TOWER BOLT SECTION	SCALE	3:1
		AREA mm ²	104.865
		PERIMETER mm.	71.251
		WEIGHT kg/m	0.283
		DRAWING No.	SECTION No.
		P-21861	
		18102	18102