

P-21752-2

18103

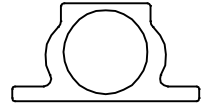

1:1

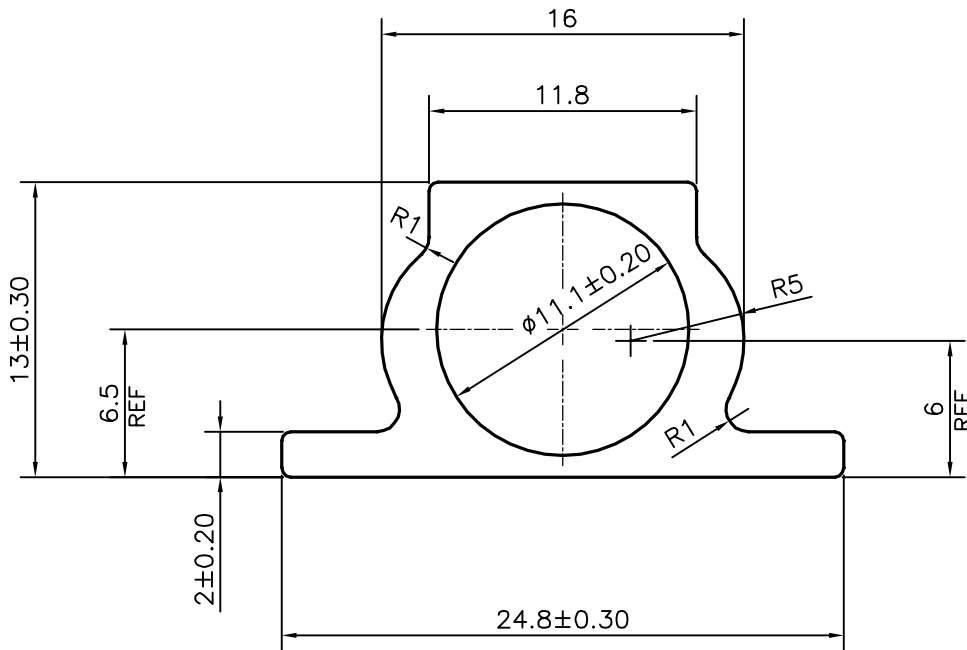

APPROXIMATE WEIGHT RANGE - 0.263 - 0.321 kg/m



SYMBOL OF QUALITY
AN ISO 9001 COMPANY

JINDAL ALUMINIUM LTD.
BANGALORE-560073 (INDIA)

	NAME	DATE
DRAWN	J.P.KAUSHIK	21-12-2020
CHECKED		
APPROVED	B.NATARAJA	24-12-2020
SCALE		3:1
AREA mm ²		108.255
PERIMETER mm.		72.642
WEIGHT kg/m		0.292
DRAWING No.	SECTION No.	
P-21752-2	-	
18103	18103	

1. ALL DIMENSIONS ARE IN mm.
2. ROUND OFF ALL SHARP CORNERS WITH 0.40 mm.
3. TOLERANCES WILL BE AS PER IS:6477-1983 , UNLESS OTHERWISE SPECIFIED

PARTY'S NAME	IMPERIAL METAL MART, DELHI
PARTY'S DRAWING No.	AS PER SAMPLE & REQUIREMENT
ALLOY & TEMPER	HE9 WP A3D
DESCRIPTION	TOWER BOLT