

P-21899

18105

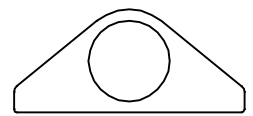

1:1

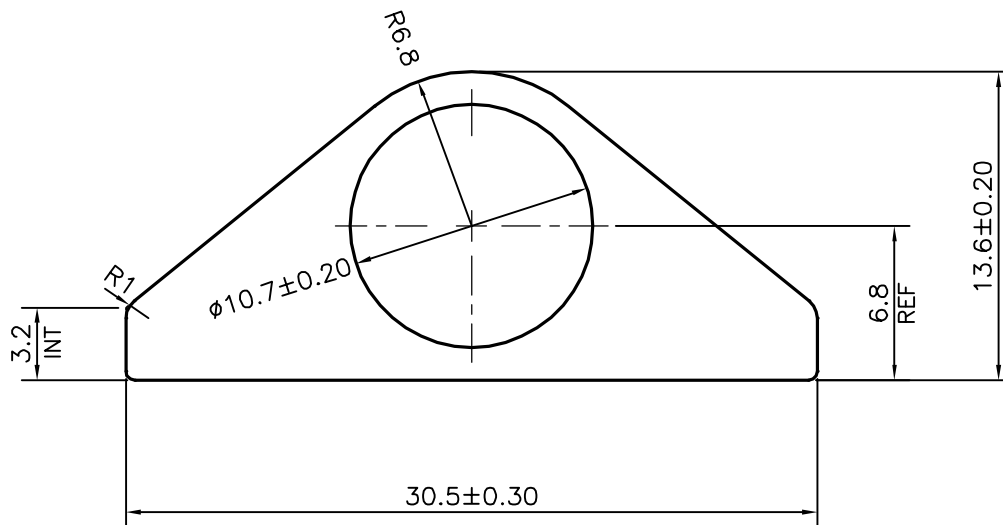

APPROXIMATE WEIGHT RANGE - 0.462 - 0.564 kg/m



SYMBOL OF QUALITY  
AN ISO 9001 COMPANY

**JINDAL ALUMINIUM LTD.**  
BANGALORE-560073 (INDIA)

	NAME	DATE
DRAWN	J.P.KAUSHIK	23-12-2020
CHECKED		
APPROVED	B.NATARAJA	31-12-2020
SCALE		3:1
AREA mm <sup>2</sup>		189.918
PERIMETER mm.		73.92
WEIGHT kg/m		0.513
DRAWING No.	SECTION No.	
P-21899	-	
18105	18105	

1. ALL DIMENSIONS ARE IN mm.
2. ROUND OFF ALL SHARP CORNERS WITH 0.40 mm.
3. TOLERANCES WILL BE AS PER IS:6477-1983 UNLESS OTHERWISE SPECIFIED

PARTY'S NAME	ALUMINIUM TRADING COMPANY, NEW DELHI
PARTY'S DRAWING No.	AS PER DRAWING
ALLOY & TEMPER	HE9 WP A3D
DESCRIPTION	TOWER BOLT SECTION