

P-22818

18113

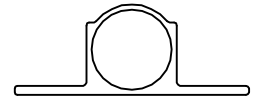

SCALE: -1:1

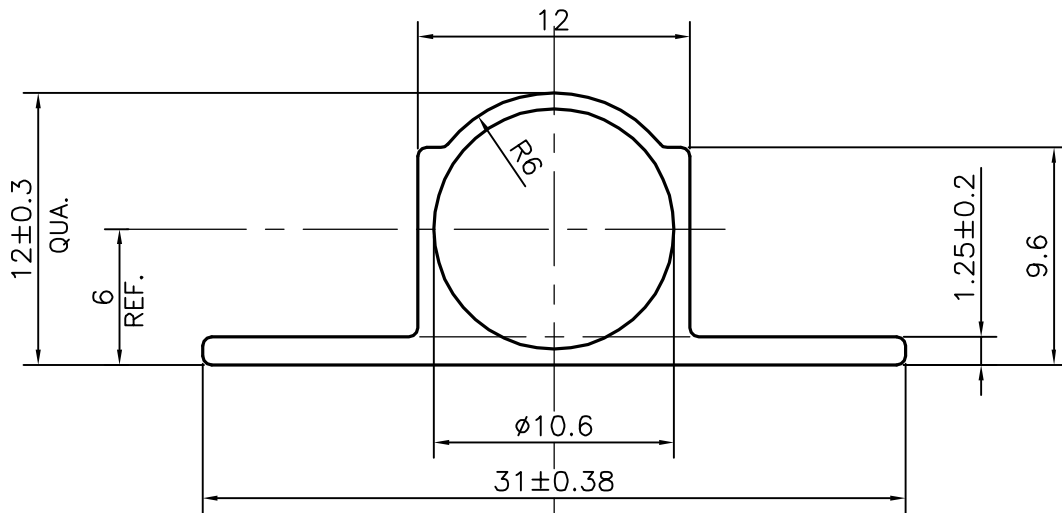

SCALE: -3:1

3658 mm LONG PIECES IN 100 Kgs 152 PIECES (AVERAGE)

## TOLERANCES ON OVERALL DIMENSIONS OF HOLLOW SECTIONS

UPTO 20.0mm - ±0.30  
 UPTO 30.0mm - ±0.38  
 UPTO 40.0mm - ±0.45  
 UPTO 50.0mm - ±0.52  
 UPTO 60.0mm - ±0.60

UPTO 80.0mm - ±0.70  
 UPTO 100.0mm - ±0.80  
 UPTO 120.0mm - ±0.90  
 UPTO 140.0mm - ±1.00  
 UPTO 160.0mm - ±1.14

UPTO 180.0mm - ±1.27  
 UPTO 200.0mm - ±1.40  
 UPTO 225.0mm - ±1.52

1. STRAIGHTNESS=1.7mm/M  
 2. TWIST=1.7mm/M  
 3. ANGULARITY= ±2°  
 4. FLATNESS =0.006xWIDTH



SYMBOL OF QUALITY  
 AN ISO 9001 COMPANY

**JINDAL ALUMINIUM LTD.**  
 BANGALORE-560073 (INDIA)

	NAME	DATE
DRAWN	PUNITH	26-07-2021
CHECKED		
APPROVED	B.NATARAJA	09-08-2021

- ALL DIMENSIONS ARE IN mm.
- ROUND OFF ALL SHARP CORNERS WITH 0.40 mm.
- TOLERANCES WILL BE AS PER IS:6477-1983, UNLESS OTHERWISE SPECIFIED

SCALE	1:1
AREA mm <sup>2</sup>	66.679
PERIMETER mm.	81.299
WEIGHT kg/m	0.180

PARTY'S NAME	ALUMINIUM TRADING CO., NEW DELHI	DRAWING No.	P-22818	SECTION No.	-
PARTY'S DRAWING No.	LIGHTER SECTION OF 18071		18113		18113
ALLOY & TEMPER	HE9WP A3D				
DESCRIPTION	TOWER BOLT SECTION				