

P-22903-1

18114

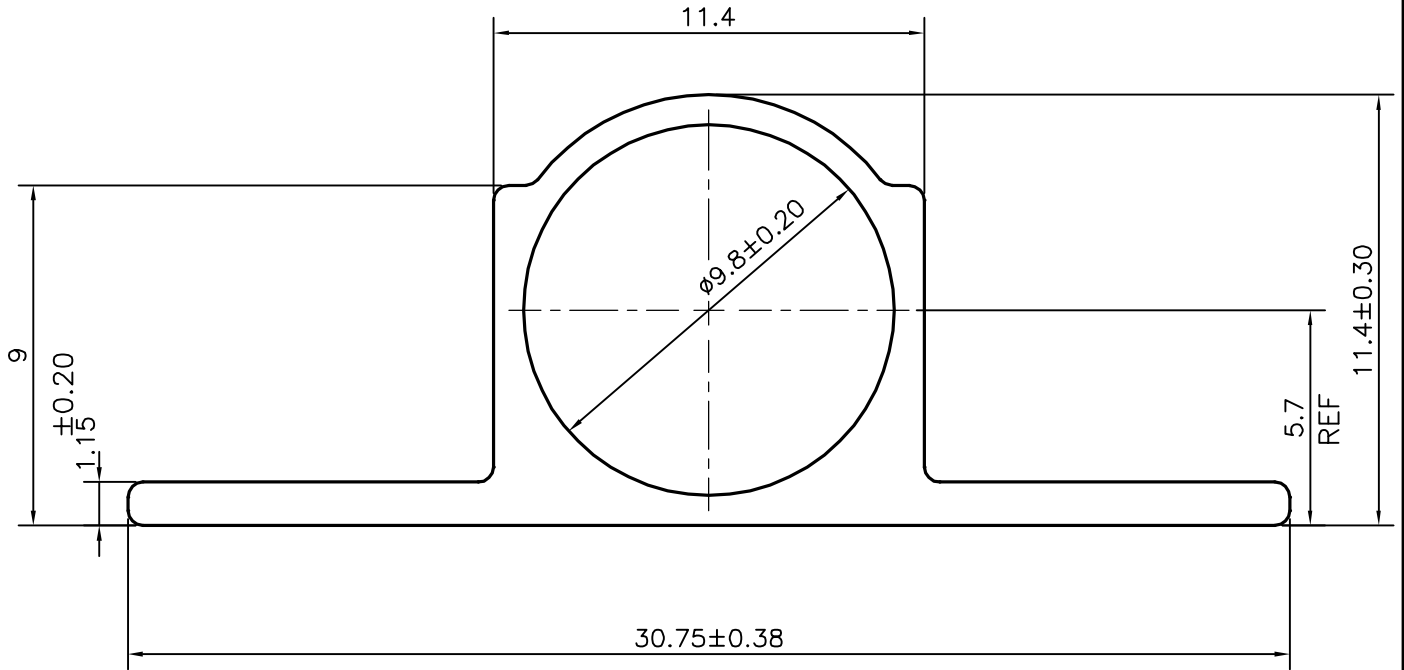

NO OF PIECES IN 100 kgs:- 156 (AVERAGE)

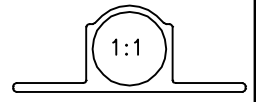

SYMBOL OF QUALITY
AN ISO 9001 COMPANY

JINDAL ALUMINIUM LTD.
BANGALORE-560073 (INDIA)

	NAME	DATE
DRAWN	J.P.KAUSHIK	23-08-2021
CHECKED		
APPROVED	B.NATARAJA	24-08-2021

1. ALL DIMENSIONS ARE IN mm.
2. ROUND OFF ALL SHARP CORNERS WITH 0.40 mm.
3. TOLERANCES WILL BE AS PER IS:6477-1983 , UNLESS OTHERWISE SPECIFIED

SCALE	5:1
AREA mm ²	64.935
PERIMETER mm.	79.64
WEIGHT kg/m	0.175

PARTY'S NAME	ALUMINIUM TRADING CO., NEW DELHI
PARTY'S DRAWING No.	AS PER DRAWING
ALLOY & TEMPER	HE9 WP A3D
DESCRIPTION	TOWER BOLT

DRAWING No.	SECTION No.
P-22903-1	-
18114	18114