

P-22914-1

18115

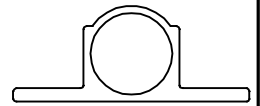

1:1

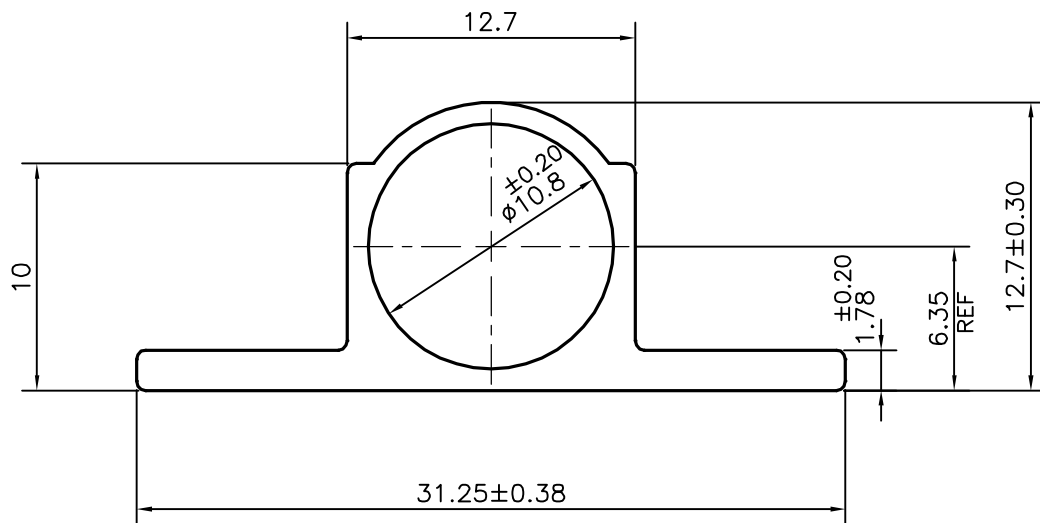

NO OF PIECES IN 100 kgs:- 115 (AVERAGE)



SYMBOL OF QUALITY  
AN ISO 9001 COMPANY

**JINDAL ALUMINIUM LTD.**  
BANGALORE-560073 (INDIA)

	NAME	DATE
DRAWN	J.P.KAUSHIK	28-08-2021
CHECKED		
APPROVED	B.NATARAJA	17/09/2021
SCALE		3:1
AREA mm <sup>2</sup>		87.953
PERIMETER mm.		82.906
WEIGHT kg/m		0.237
DRAWING No.		SECTION No.
P-22914-1		-
18115		18115

1. ALL DIMENSIONS ARE IN mm.
2. ROUND OFF ALL SHARP CORNERS WITH 0.40 mm.
3. TOLERANCES WILL BE AS PER IS:6477-1983 , UNLESS OTHERWISE SPECIFIED

PARTY'S NAME	ALUMINIUM TRADING CO., NEW DELHI
PARTY'S DRAWING No.	AS PER DRAWING
ALLOY & TEMPER	HE9 WP A3D
DESCRIPTION	TOWER BOLT