

P-22991-1

18117

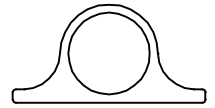

1:1

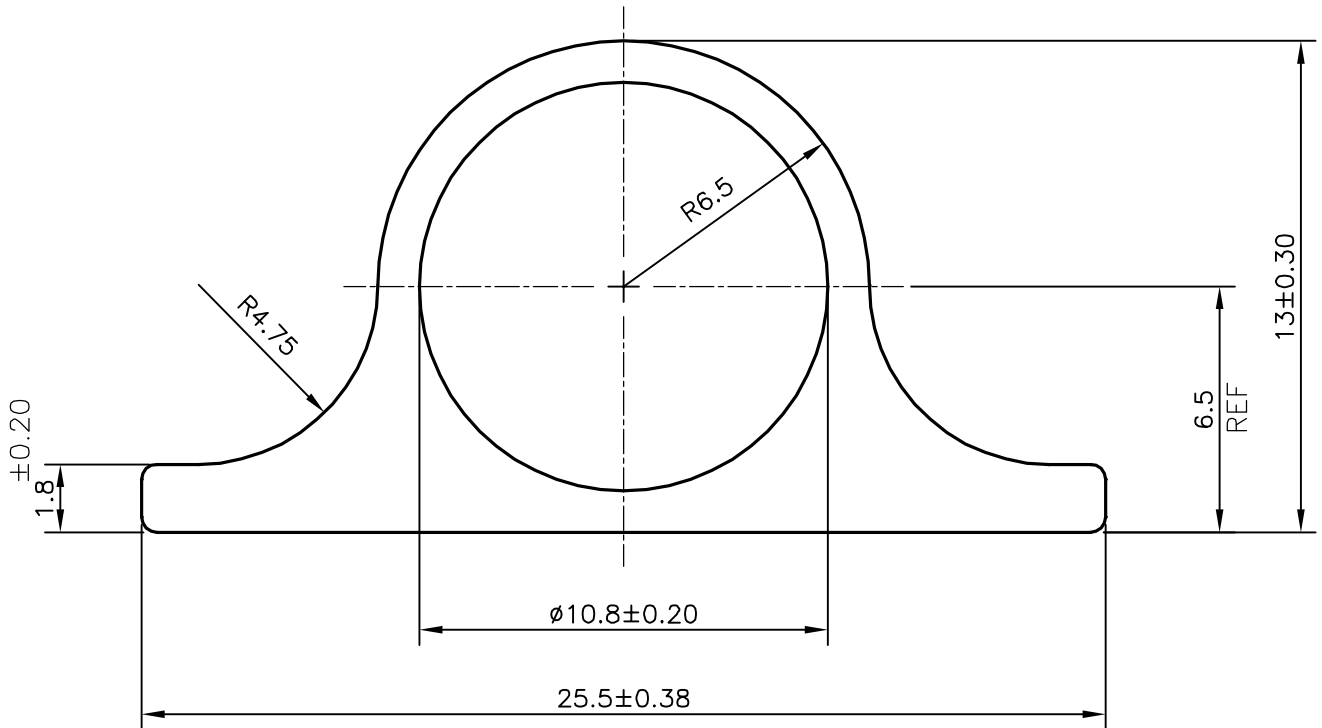

1. STRAIGHTNESS=1.7mm/M
2. TWIST=1.7mm/M
3. ANGULARITY=  $\pm 2^\circ$
4. FLATNESS =0.007xWIDTH

APPROXIMATE WEIGHT RANGE -0.222 - 0.272 kg/m



SYMBOL OF QUALITY  
AN ISO 9001 COMPANY

**JINDAL ALUMINIUM LTD.**  
BANGALORE-560073 (INDIA)

	NAME	DATE
DRAWN	J.P.KAUSHIK	24-09-2021
CHECKED		
APPROVED	B.NATARAJA	07/10/2021
SCALE		5:1
AREA mm <sup>2</sup>		91.303
PERIMETER mm.		66.656
WEIGHT kg/m		0.247
DRAWING No.	SECTION No.	
P-22991-1	-	
18117	18117	

1. ALL DIMENSIONS ARE IN mm.
2. ROUND OFF ALL SHARP CORNERS WITH 0.40 mm.
3. TOLERANCES WILL BE AS PER IS:6477-1983 , UNLESS OTHERWISE SPECIFIED

PARTY'S NAME	IMPERIAL METAL MART, DELHI
PARTY'S DRAWING No.	AS PER DRAWING
ALLOY & TEMPER	HE9 WP-A3D
DESCRIPTION	TOWER BOLT SECTION