

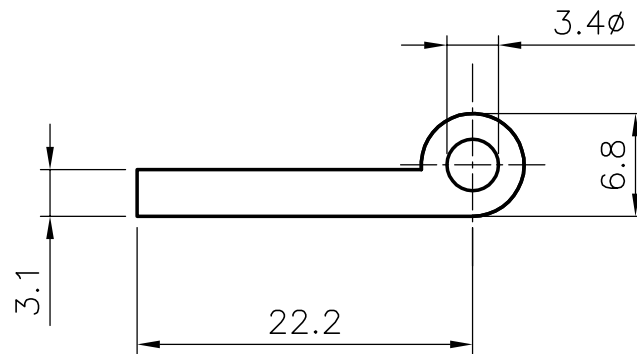

4085

18359



 SYMBOL OF QUALITY AN ISO 9002 COMPANY	JINDAL ALUMINIUM LTD. <i>BANGALORE-560073 (INDIA)</i>		NAME	DATE
		DRAWN	-	27-02-01
1. ALL DIMENSIONS ARE IN mm. 2. ROUND OFF ALL SHARP CORNERS WITH 0.40 mm. 3. TOLERANCES WILL BE AS PER IS:6477-1983 UNLESS OTHERWISE SPECIFIED		CHECKED		
		APPROVED		
PARTY'S NAME		ARROW ELECTRICAL INDUSTRIES CANNANORE-11	SCALE	2:1
PARTY'S DRAWING No.		-	WEIGHT kg/m	0.237
ALLOY & TEMPER		HE9 WP	SECTION No.	18359
DESCRIPTION		SPL. HOLLOW HINGES	DRAWING No. 18359	