

4072

18406

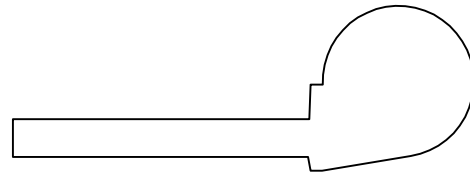

1:1

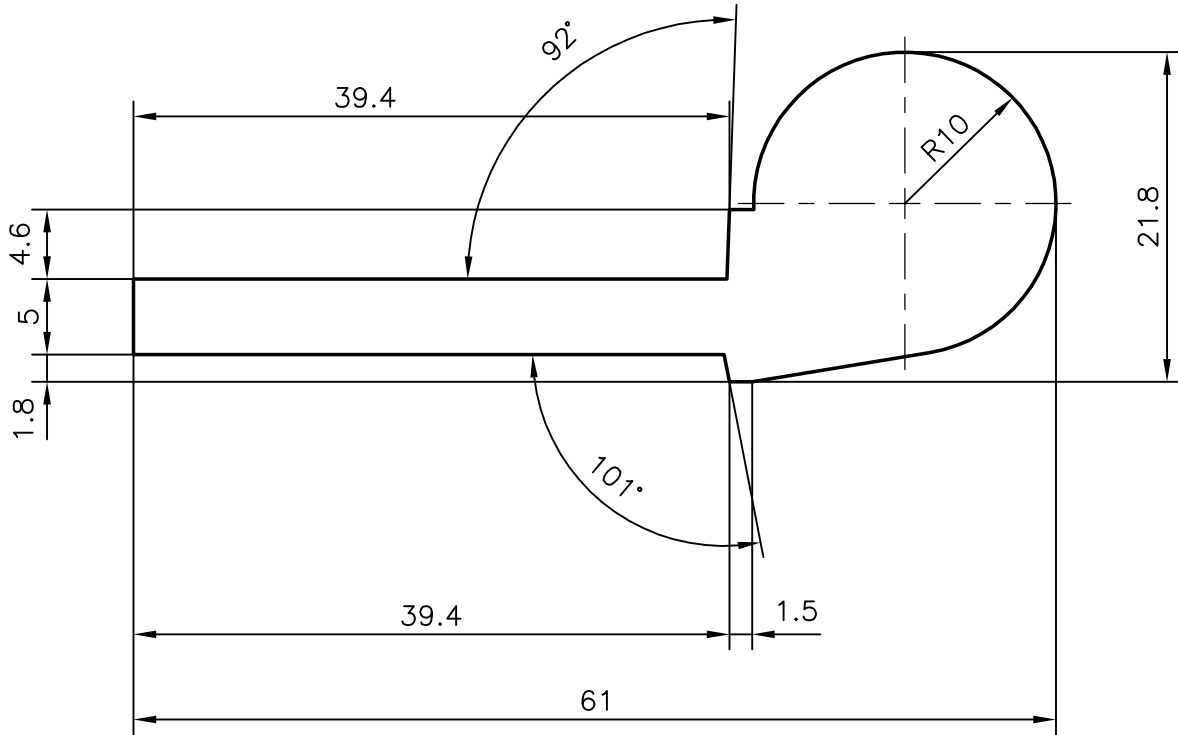

JINDAL ALUMINIUM LTD.

BANGALORE-560073

NAME

DATE

DRAWN

R.D.Sharma

24-12-96

1. ALL DIMENSIONS ARE IN mm.
2. ROUND OFF ALL SHARP CORNERS WITH 0.4 mm.
3. TOLERANCES WILL BE AS PER IS: 3965-1981 ,UNLESS OTHERWISE SPECIFIED

CHECKED

APPROVED

PARTY'S NAME

-

SCALE

2:1

PARTY'S DRAWING No.

-

WEIGHT kg/m

1.515

ALLOY & TEMPER

HE9 WP

SECTION No.

18406

LENGTH

3658 mm.

DRAWING No.

DESCRIPTION

SPECIAL HINGE

18406