

P-7358

S2017

18425

SCALE 1:1

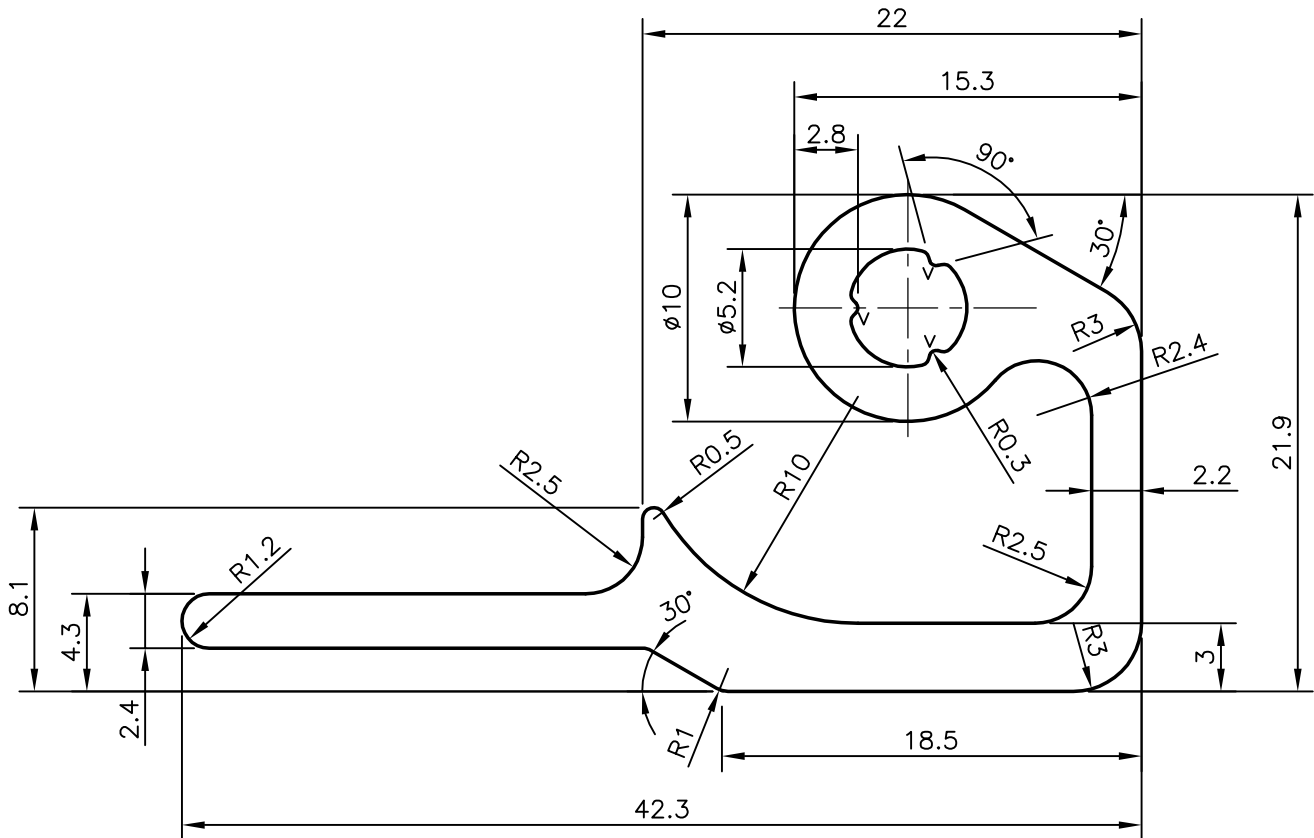
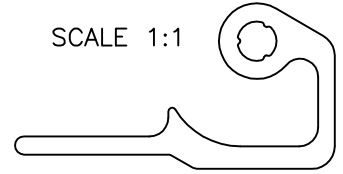

V = 'V'-GROOVE 0.4x90° (3 PLACES)



SYMBOL OF QUALITY  
AN ISO 9001 COMPANY

**JINDAL ALUMINIUM LTD.**  
BANGALORE-560073 (INDIA)

	NAME	DATE
DRAWN	PRASANN.H	22-06-2007
CHECKED		
APPROVED		
SCALE		3:1
AREA mm <sup>2</sup>		233.931
PERIMETER mm.		149.424
WEIGHT kg/m		0.632
DRAWING No.	SECTION No.	
P-7358	-	
S2017	S2017	
18425	18425	

1. ALL DIMENSIONS ARE IN mm.
2. ROUND OFF ALL SHARP CORNERS WITH 0.40 mm.
3. TOLERANCES WILL BE AS PER IS:6477-1983 UNLESS OTHERWISE SPECIFIED

PARTY'S NAME	N-RACK ACCESSORIES, BANGALORE
PARTY'S DRAWING No.	AS PER SAMPLE
ALLOY & TEMPER	6063 T6
DESCRIPTION	HINGE SECTION