

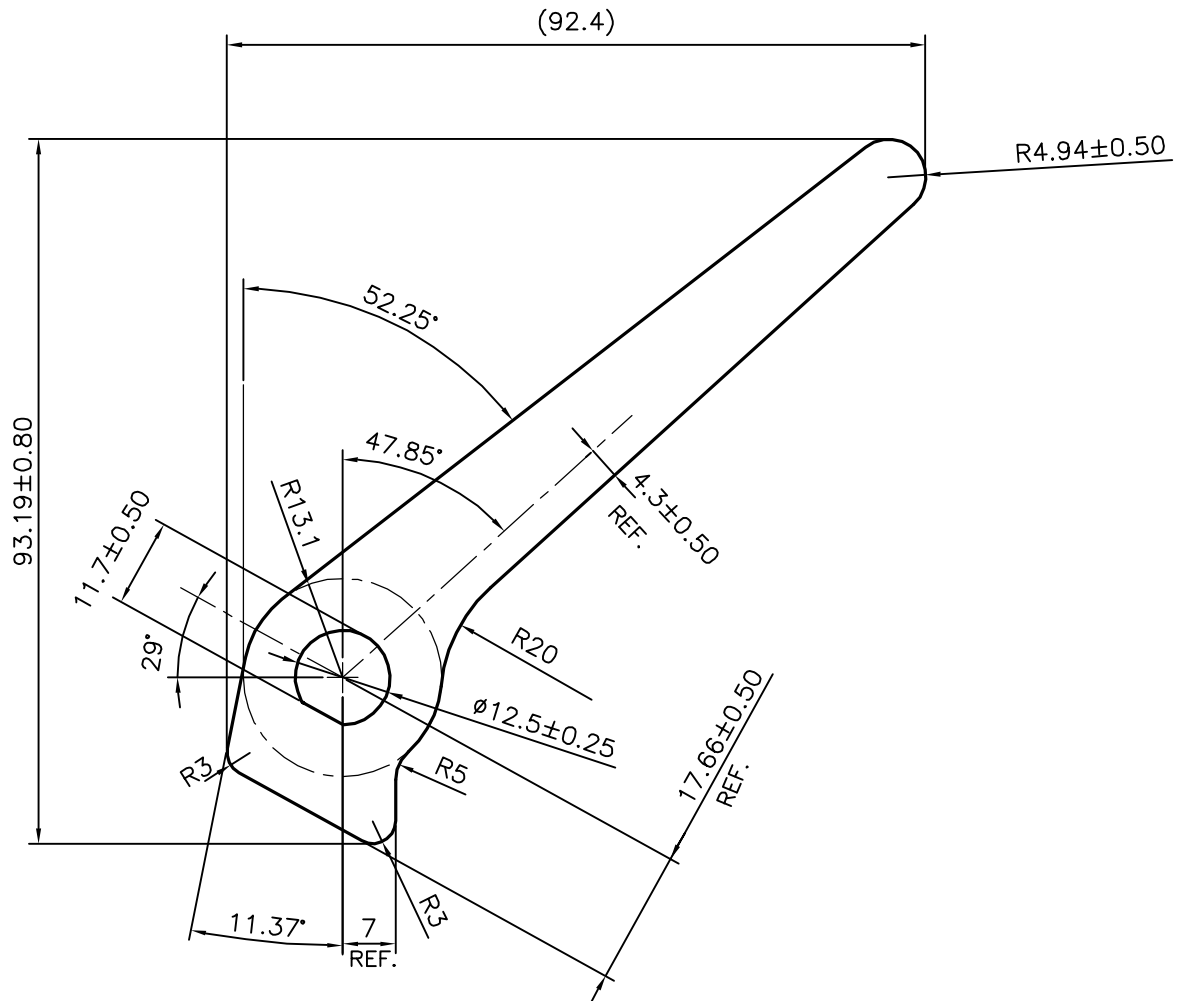

| |
|-----------|
| P-16854-1 |
| S5315 |
| 18428 |



TOLERANCES ON OVERALL DIMENSIONS OF HOLLOW SECTIONS

| | | | |
|---------------------|----------------------|----------------------|---|
| UPTO 20.0mm - ±0.30 | UPTO 80.0mm - ±0.70 | UPTO 180.0mm - ±1.27 | 1. STRAIGHTNESS=1.7mm/M 2. TWIST=1.7mm/M 3. ANGULARITY= ±2° 4. FLATNESS =0.006xWIDTH |
| UPTO 30.0mm - ±0.38 | UPTO 100.0mm - ±0.80 | UPTO 200.0mm - ±1.40 | |
| UPTO 40.0mm - ±0.45 | UPTO 120.0mm - ±0.90 | UPTO 225.0mm - ±1.52 | |
| UPTO 50.0mm - ±0.52 | UPTO 140.0mm - ±1.00 | | |
| UPTO 60.0mm - ±0.60 | UPTO 160.0mm - ±1.14 | | |

| | | | |
|--|--|----------------------|-------------|
|  SYMBOL OF QUALITY AN ISO 9001 COMPANY | JINDAL ALUMINIUM LTD. BANGALORE-560073 (INDIA) | NAME | DATE |
| | | DRAWN | J.P.KAUSHIK |
| | | CHECKED | |
| | | APPROVED | B.NATARAJ |
| | | | 02-03-2017 |
| 1. ALL DIMENSIONS ARE IN mm. 2. ROUND OFF ALL SHARP CORNERS WITH 0.50 mm. 3. TOLERANCES WILL BE AS PER IS:6477-1983 UNLESS OTHERWISE SPECIFIED | | SCALE | 1:1 |
| | | AREA mm ² | 1781.938 |
| | | PERIMETER mm. | 273.101 |
| | | WEIGHT kg/m | 4.811 |
| | | DRAWING No. | SECTION No. |
| PARTY'S NAME | SOLIDUS HI-TECH PRODUCTS PVT. LTD.,BANGALORE | P-16854-1 | - |
| PARTY'S DRAWING No. | AS PER AutoCAD DRAWING-W11047222 REV.A | S5315 | S5315 |
| ALLOY & TEMPER | 6060 T6 | 18428 | 18428 |
| DESCRIPTION | MISC. SECTION | | |