

4203

18453

-

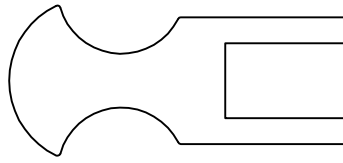

1:1

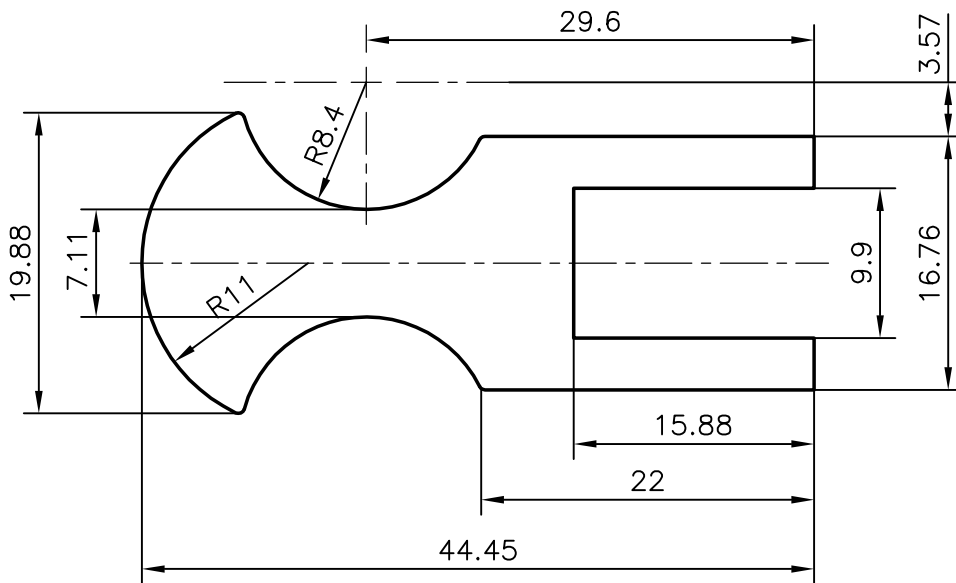

JINDAL ALUMINIUM LTD.
BANGALORE-560073

NAME

DATE

DRAWN

R.D.Sharma

29-7-95

CHECKED

APPROVED

1. ALL DIMENSIONS ARE IN mm.
2. ROUND OFF ALL SHARP CORNERS WITH 0.4 mm.
3. TOLERANCES WILL BE AS PER IS : 3965-1981
UNLESS OTHERWISE SPECIFIED

PARTY'S NAME

-

SCALE

2:1

PARTY'S DRAWING No.

-

WEIGHT kg/m

1.265

ALLOY & TEMPER

HE9 WP

SECTION No.

18453

LENGTH

3658 mm.

DRAWING No.

18453

DESCRIPTION

LATCH HANDLE