

4264

14341

18570

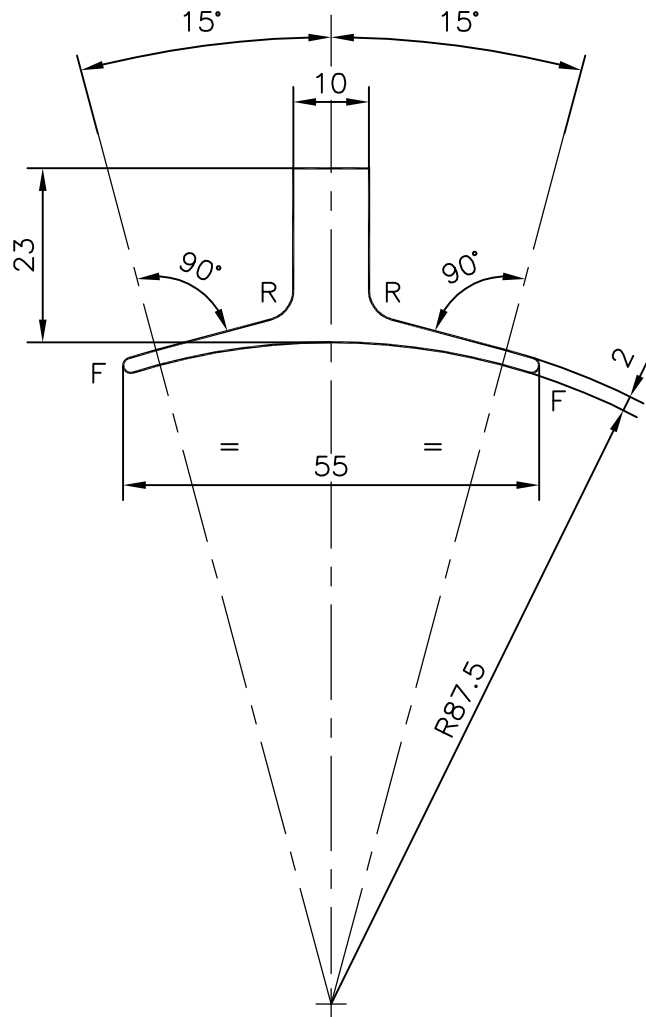

R = 4 RADIUS (2)  
F = FULL RADIUS (2)

2

ALLOY &amp; TEMPER CHANGED FROM HE30 TO HE9 WP

ISSUE

DESCRIPTION

CHD BY

APPD BY

## REVISION

**JINDAL ALUMINIUM LTD.****BANGALORE-560073**

NAME

DATE

DRAWN

R.D.Sharma

28-01-97

CHECKED

APPROVED

1. ALL DIMENSIONS ARE IN mm.  
2. ROUND OFF ALL SHARP CORNERS WITH 0.4 mm.  
3. TOLERANCES WILL BE AS PER IS: 3965-1981 ,UNLESS OTHERWISE SPECIFIED

PARTY'S NAME

INDIA (ALUMINIUM) TRADING CO., MADRAS

SCALE

1:1

PARTY'S DRAWING No.

-

WEIGHT kg/m

0.942

ALLOY &amp; TEMPER (2)

HE9 WP

SECTION No.

18570

LENGTH

AS REQUIRED

DRAWING No.

DESCRIPTION

HANDLE SECTION

18570