

4271

14347

18577

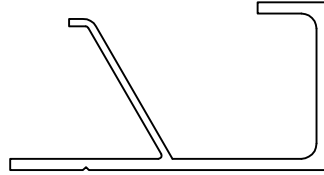

1;1

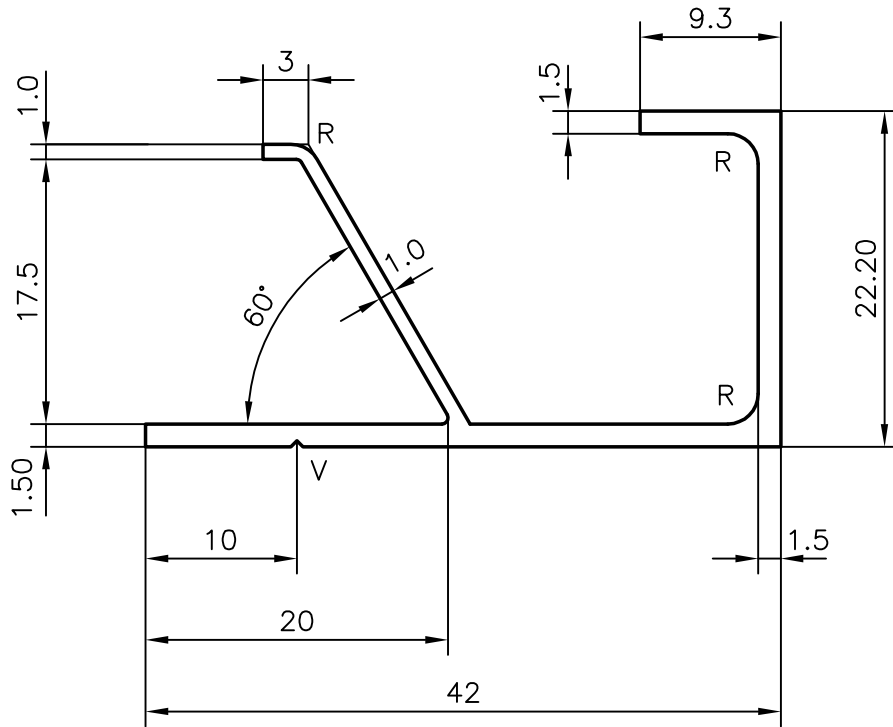

R = RADIUS 2.0 (3)

V = 0.4 x 90° VEE GROOVE

JINDAL ALUMINIUM LTD.**BANGALORE-560073**

NAME

DATE

DRAWN

R.D.Sharma

05-06-97

CHECKED

APPROVED

1. ALL DIMENSIONS ARE IN mm.
 2. ROUND OFF ALL SHARP CORNERS WITH 0.4 mm.
 3. TOLERANCES WILL BE AS PER IS: 3965-1981 ,UNLESS OTHERWISE SPECIFIED

PARTY'S NAME FEATHERLITE PRODUCTS, BANGALORE

SCALE

2:1

PARTY'S DRAWING No.

-

WEIGHT kg/m

0.351

ALLOY & TEMPER

HE9 WP

SECTION No.

18577

LENGTH

AS REQUIRED

DRAWING No.

DESCRIPTION

HANDLE SECTION

18577