

P-4203

14356

18614

WEIGHT PER PIECE (12') :- 5.500-5.700 kg

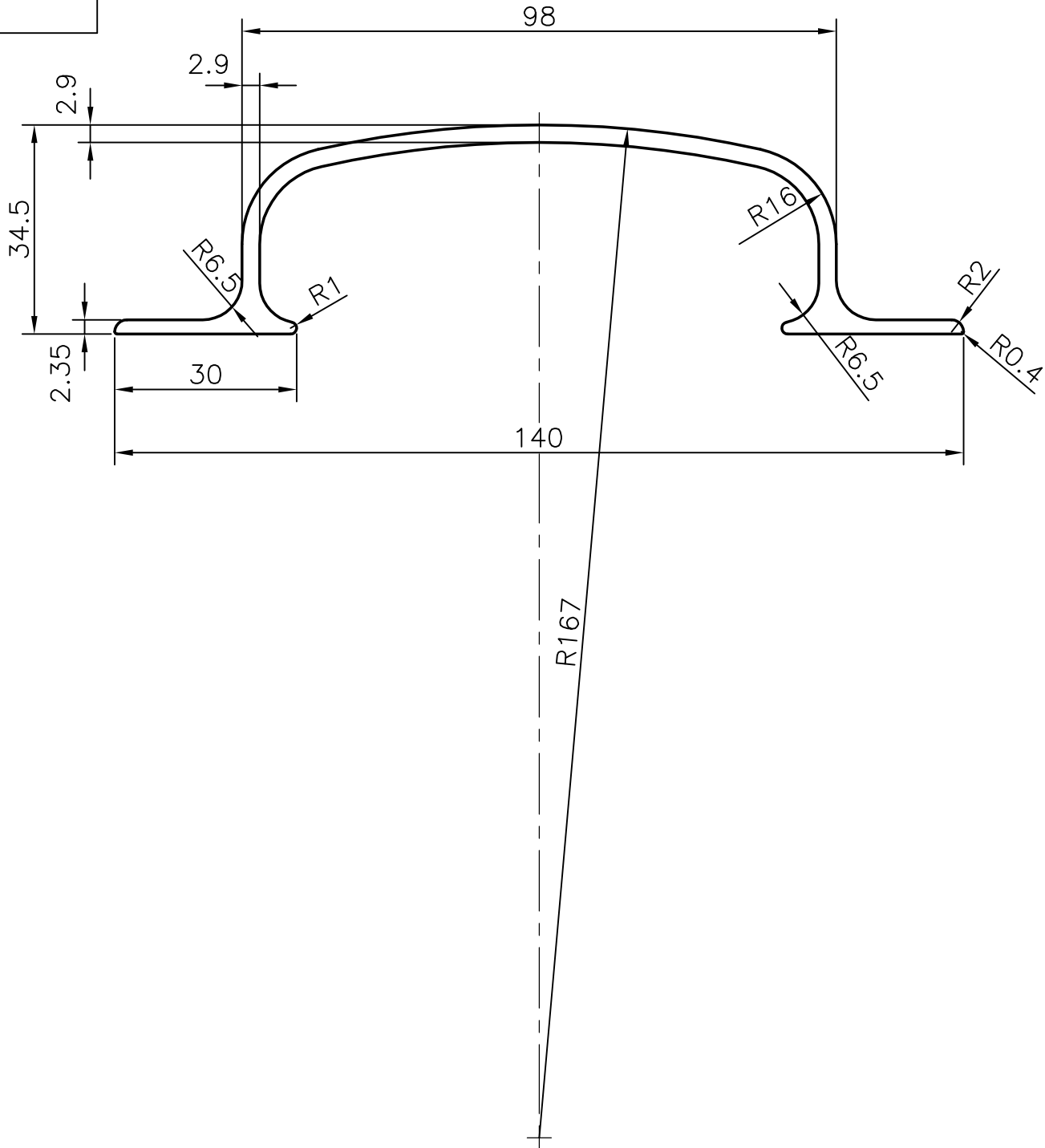

SYMBOL OF QUALITY
AN ISO 9002 COMPANY

JINDAL ALUMINIUM LTD.
BANGALORE-560073 (INDIA)

	NAME	DATE
DRAWN	R.D.Sharma	25-04-2003
CHECKED		
APPROVED		

1. ALL DIMENSIONS ARE IN mm.
2. ROUND OFF ALL SHARP CORNERS WITH 0.40 mm.
3. TOLERANCES WILL BE AS PER IS 3965-1981 UNLESS OTHERWISE SPECIFIED

SCALE	1:1
AREA mm ²	566.9
PERIMETER mm.	383.4
WEIGHT kg/m	1.531

PARTY'S NAME	GENERAL CATEGORY, DELHI MARKET
PARTY'S DRAWING No.	LIGHTER OF SECTION NO. 18595
ALLOY & TEMPER	HE9 WP
DESCRIPTION	'C' HANDLE SECTION

DRAWING No.	SECTION No.
P-4203	-
14356	14356
18614	18614