

P-5315-1

18636

AVERAGE WEIGHT:- 4.941 kg/ 3658 mm.

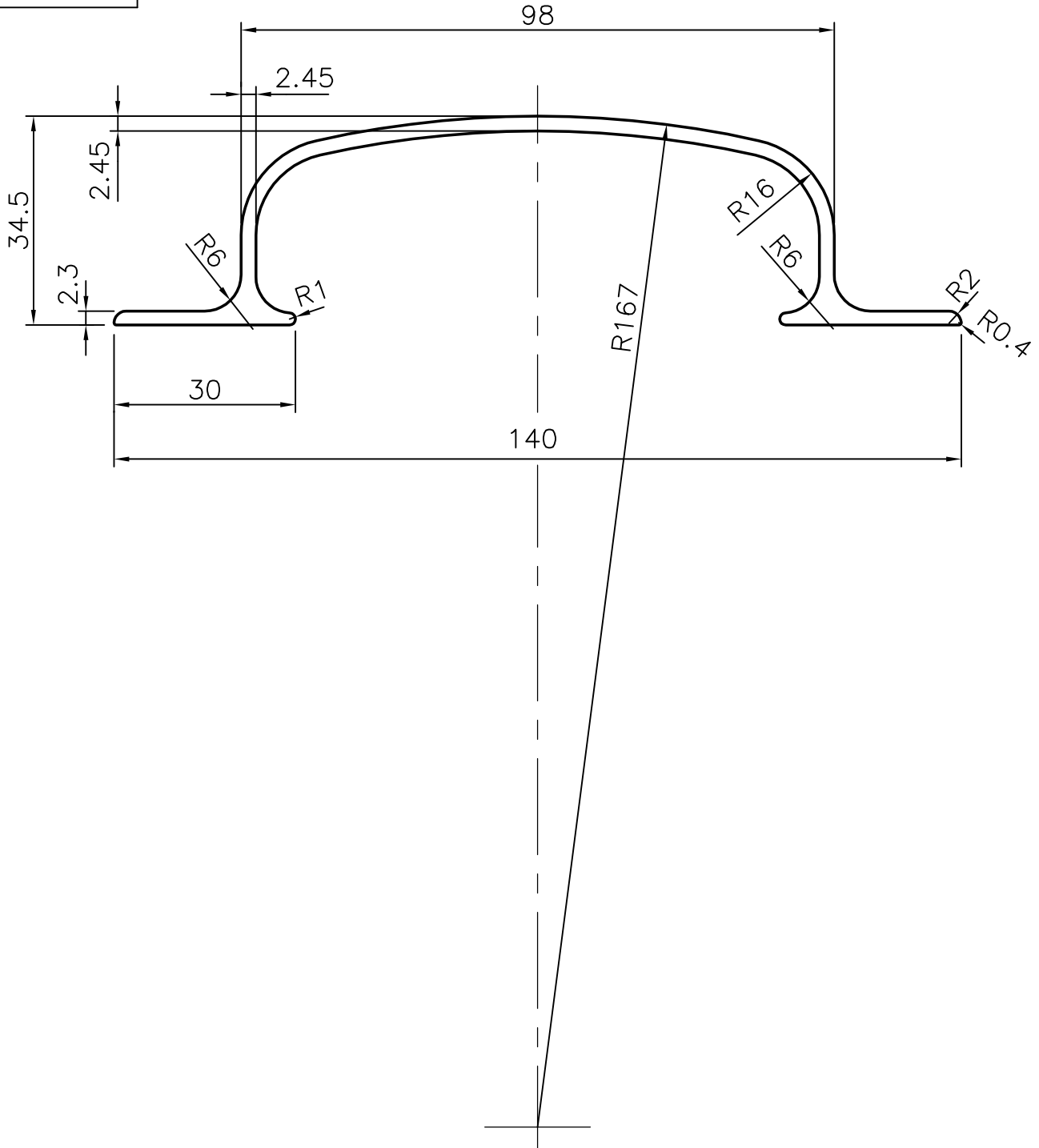

SYMBOL OF QUALITY  
AN ISO 9001 COMPANY

**JINDAL ALUMINIUM LTD.**  
BANGALORE-560073 (INDIA)

	NAME	DATE
DRAWN	MALINGAPPA	01.03.2005
CHECKED		
APPROVED		

1. ALL DIMENSIONS ARE IN mm.
2. ROUND OFF ALL SHARP CORNERS WITH 0.40 mm.
3. TOLERANCES WILL BE AS PER IS: 3965-1981 UNLESS OTHERWISE SPECIFIED

SCALE	1:1
AREA mm <sup>2</sup>	500.407
PERIMETER mm.	386.36
WEIGHT kg/m	1.351

PARTY'S NAME	GENERAL CATEGORY, DELHI MARKET
PARTY'S DRAWING No.	LIGHTER OF SECTION NO.18614
ALLOY & TEMPER	HE9 WP
DESCRIPTION	'C' HANDLE SECTION

DRAWING No.	SECTION No.
P-5315-1	-
18636	18636