

P-18331

18646

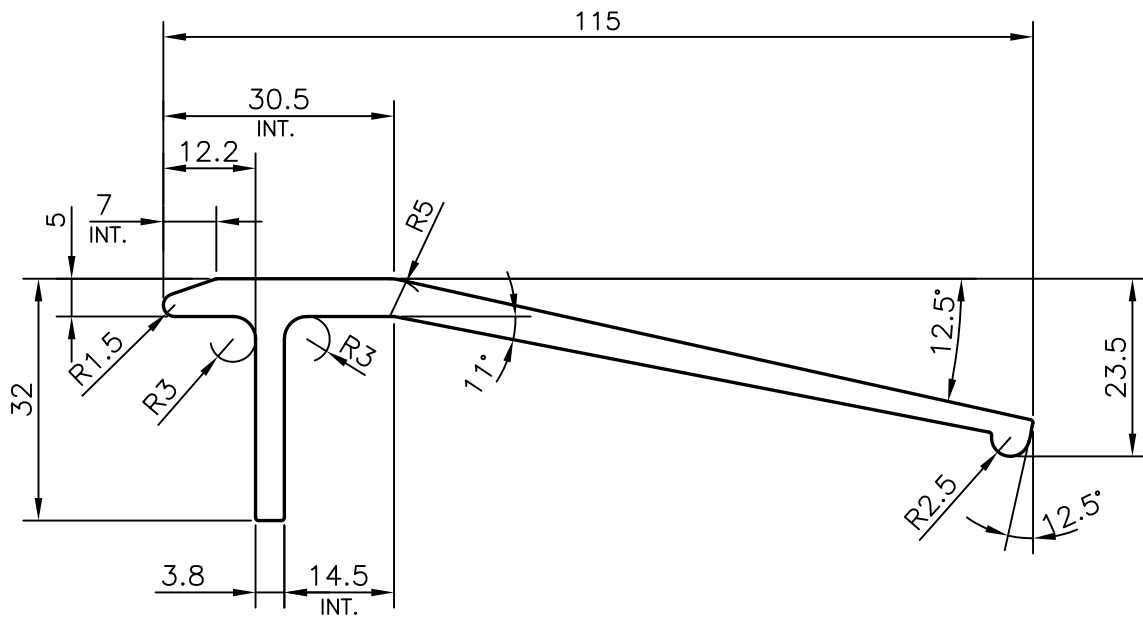

## TOLERANCES ON OVERALL WIDTHS &amp; WIDTHS ACROSS FLATS OF BARS, &amp; REGULAR SECTIONS

UPTO 6.40mm - $\pm 0.20$	UPTO 32.0mm - $\pm 0.38$	UPTO 120.0mm - $\pm 0.85$	1. STRAIGHTNESS=1.7mm/M 2. TWIST=1.7mm/M 3. ANGULARITY= $\pm 2^\circ$ 4. FLATNESS =0.006xWIDTH
UPTO 10.0mm - $\pm 0.23$	UPTO 50.0mm - $\pm 0.46$	UPTO 160.0mm - $\pm 1.02$	
UPTO 12.0mm - $\pm 0.25$	UPTO 60.0mm - $\pm 0.53$	UPTO 200.0mm - $\pm 1.14$	
UPTO 16.0mm - $\pm 0.28$	UPTO 80.0mm - $\pm 0.69$	UPTO 250.0mm - $\pm 1.40$	
UPTO 25.0mm - $\pm 0.30$	UPTO 100.0mm - $\pm 0.75$	UPTO 300.0mm - $\pm 1.65$	



SYMBOL OF QUALITY  
AN ISO 9001 COMPANY

**JINDAL ALUMINIUM LTD.**  
BANGALORE-560073 (INDIA)

	NAME	DATE
DRAWN	PARVESH	20-06-2018
CHECKED		
APPROVED	B.NATARAJA	05-07-2018

- ALL DIMENSIONS ARE IN mm.
- ROUND OFF ALL SHARP CORNERS WITH 0.4 mm.
- TOLERANCES WILL BE AS PER IS:3965-1981 , UNLESS OTHERWISE SPECIFIED

SCALE	1:1
AREA mm <sup>2</sup>	584.67
PERIMETER mm.	291.8
WEIGHT kg/m	1.579
DRAWING No.	SECTION No.

PARTY'S NAME GENERAL CATEGORY, DELHI MARKET

PARTY'S DRAWING No. AS PER SAMPLE

ALLOY & TEMPER HE9 WP

DESCRIPTION HANDLE SECTION

P-18331  
18646

18646