

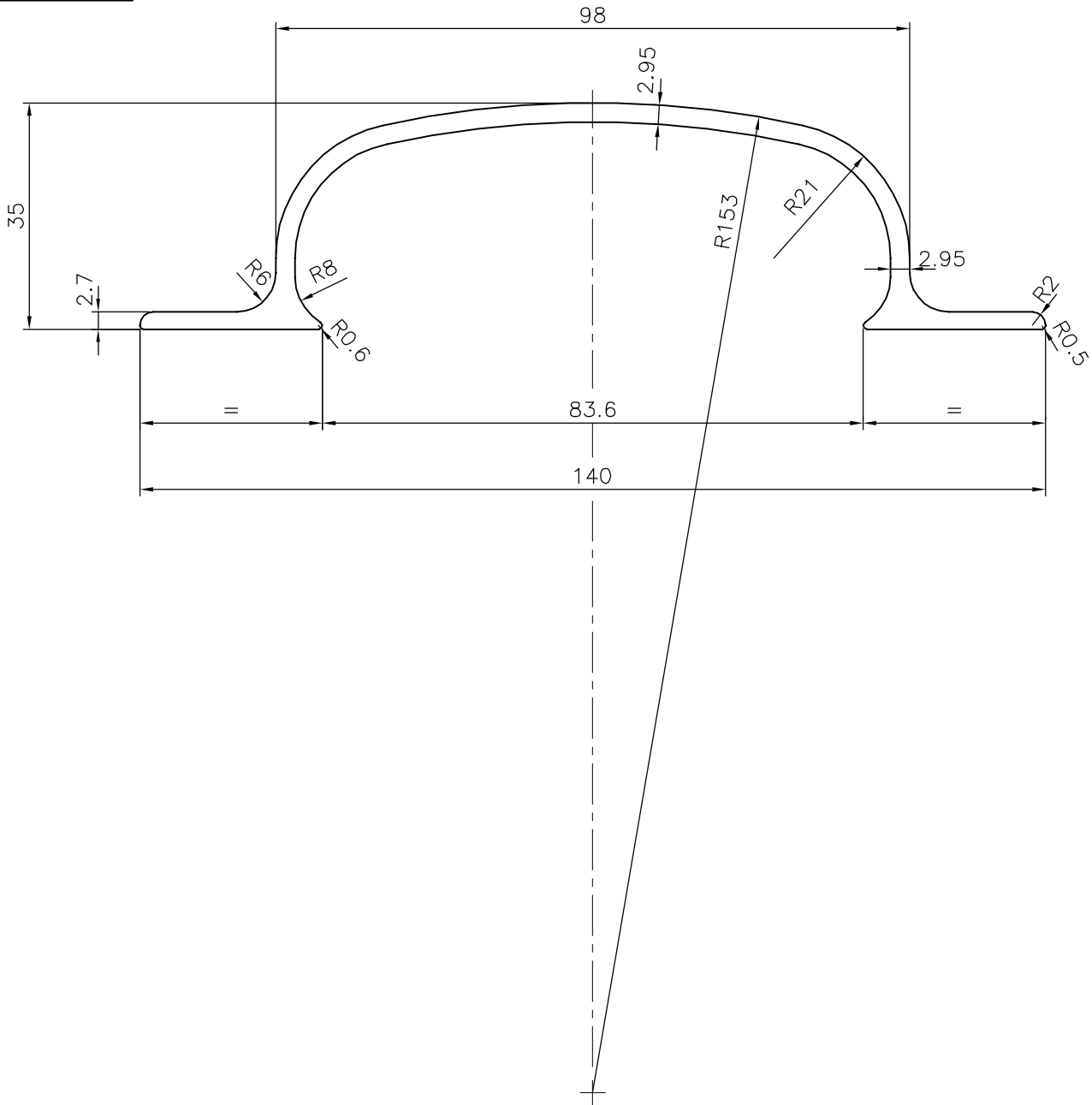

P-18479-1
X2371
18652



 SYMBOL OF QUALITY AN ISO 9001 COMPANY	JINDAL ALUMINIUM LTD. BANGALORE-560073 (INDIA)		NAME	DATE
		DRAWN	J.P.KAUSHIK	26-07-2018
1. ALL DIMENSIONS ARE IN mm. 2. ROUND OFF ALL SHARP CORNERS WITH 0.40 mm. 3. TOLERANCES WILL BE AS PER IS:3965-1981 UNLESS OTHERWISE SPECIFIED		CHECKED		
		APPROVED	B.NATARAJA	27-07-2018
PARTY'S NAME PREMIER SALES CORPORATION, NEW DELHI		SCALE		1:1
		AREA mm ²		564.479
PARTY'S DRAWING No. AS PER SAMPLE & REQUIREMENT		PERIMETER mm.		373.168
		WEIGHT kg/m		1.524
ALLOY & TEMPER HE9 WP A3D		DRAWING No.	SECTION No.	
		P-18479-1		
DESCRIPTION HANDAL SECTION		X2371	X2371	
		18652	18652	