

P-21445-1

18677

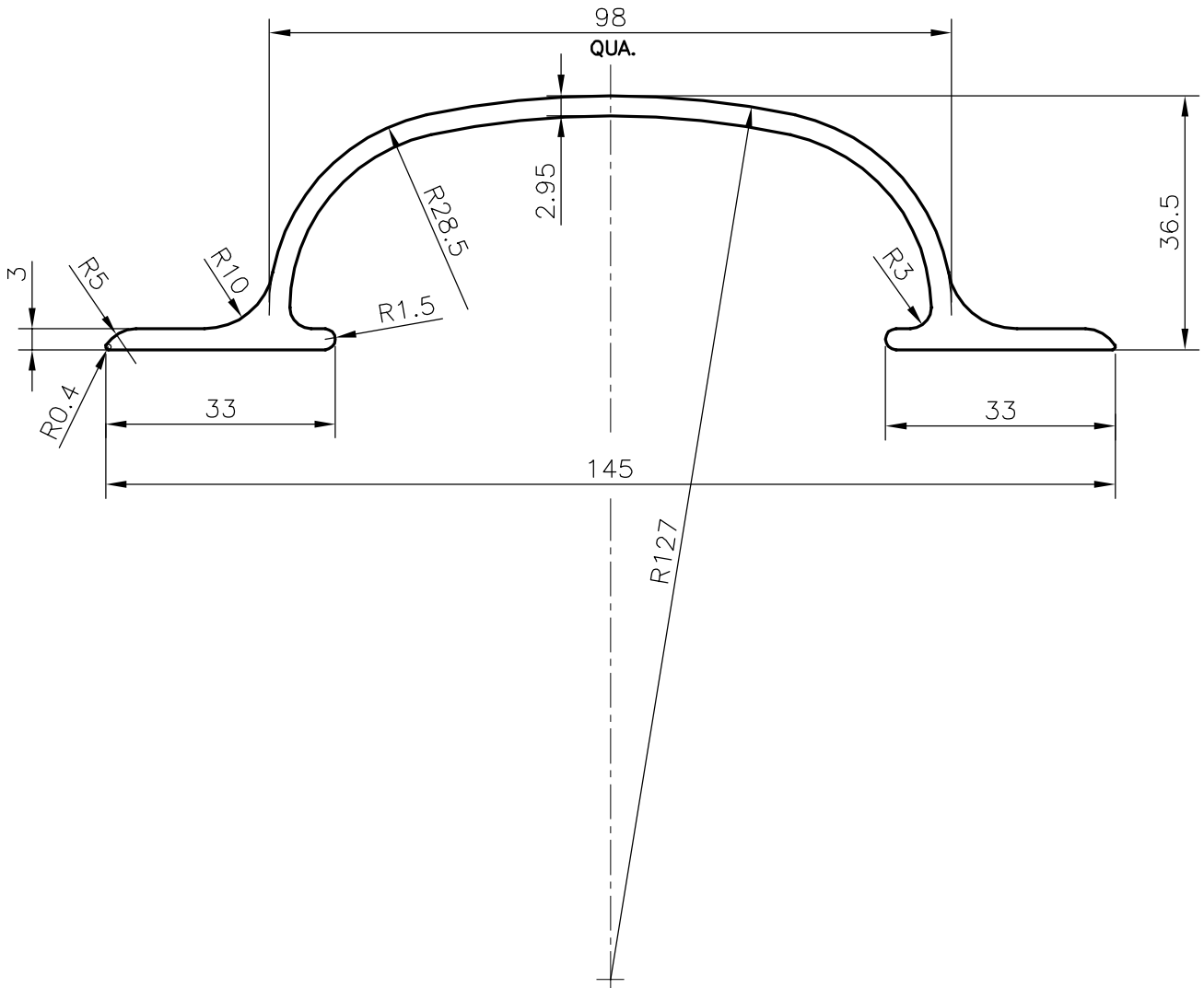

NOTE:- WEIGHT RANGE:- 5.9 TO 6.3 kg/12 FEET.
BUT NOT LESS THAN 5.9 kg/12 FEET.

TOLERANCES ON OVERALL WIDTHS & WIDTHS ACROSS FLATS OF BARS, & REGULAR SECTIONS

UPTO 6.40mm - ±0.20	UPTO 32.0mm - ±0.38	UPTO 120.0mm - ±0.85	1. STRAIGHTNESS=1.7mm/M 2. TWIST=1.7mm/M 3. ANGULARITY= ±2° 4. FLATNESS =0.007xWIDTH
UPTO 10.0mm - ±0.23	UPTO 50.0mm - ±0.46	UPTO 160.0mm - ±1.02	
UPTO 12.0mm - ±0.25	UPTO 60.0mm - ±0.53	UPTO 200.0mm - ±1.14	
UPTO 16.0mm - ±0.28	UPTO 80.0mm - ±0.69	UPTO 250.0mm - ±1.40	
UPTO 25.0mm - ±0.30	UPTO 100.0mm - ±0.75	UPTO 300.0mm - ±1.65	



SYMBOL OF QUALITY
AN ISO 9001 COMPANY

JINDAL ALUMINIUM LTD.
BANGALORE-560073 (INDIA)

	NAME	DATE
DRAWN	DARPAN	10-09-2020
CHECKED		
APPROVED	B.NATARAJA	12/09/2020

1. ALL DIMENSIONS ARE IN mm.
2. ROUND OFF ALL SHARP CORNERS WITH 0.40 mm.
3. TOLERANCES WILL BE AS PER IS:3965-1981, UNLESS OTHERWISE SPECIFIED

SCALE	1:1
AREA mm ²	616.199
PERIMETER mm.	385.868
WEIGHT kg/m	1.664

PARTY'S NAME	ATCO ALUMINIUM SYSTEMS, DELHI	DRAWING No.	P-21445-1	SECTION No.	-
PARTY'S DRAWING No.	AS PER DRAWING & REQUIREMENT		18677		18677
ALLOY & TEMPER	HE9 WP A3D				
DESCRIPTION	HANDLE SECTION				