

P-21979

18680

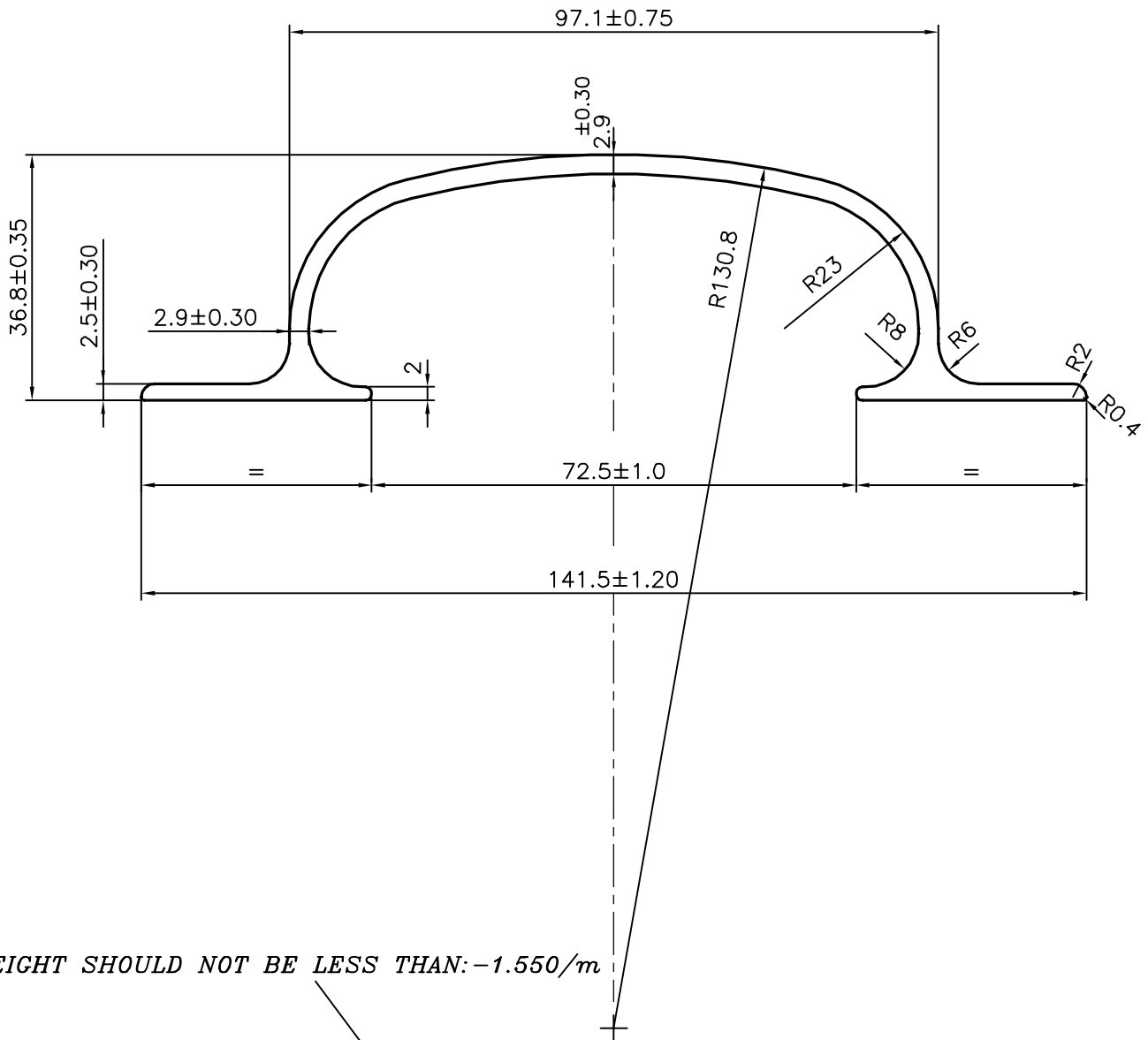

WEIGHT SHOULD NOT BE LESS THAN: $-1.550/m$

APPROXIMATE WEIGHT RANGE $-1.550 - 1.880kg/m$



SYMBOL OF QUALITY
AN ISO 9001 COMPANY

JINDAL ALUMINIUM LTD.
BANGALORE-560073 (INDIA)

	NAME	DATE
DRAWN	J.P.KAUSHIK	08-01-2021
CHECKED		
APPROVED	B.NATARAJA	16-01-2021
SCALE		1:1
AREA	mm ²	597.049
PERIMETER	mm.	397.903
WEIGHT	kg/m	1.612
DRAWING No.	SECTION No.	
P-21979		
18680	18680	

- ALL DIMENSIONS ARE IN mm.
- ROUND OFF ALL SHARP CORNERS WITH 0.40 mm.
- TOLERANCES WILL BE AS PER IS:3965-1981 UNLESS OTHERWISE SPECIFIED

PARTY'S NAME	ALUMINIUM TRADING COMPANY, DELHI
PARTY'S DRAWING No.	LIGHTER OF 18647
ALLOY & TEMPER	6063 T6
DESCRIPTION	HANDLE SECTION