

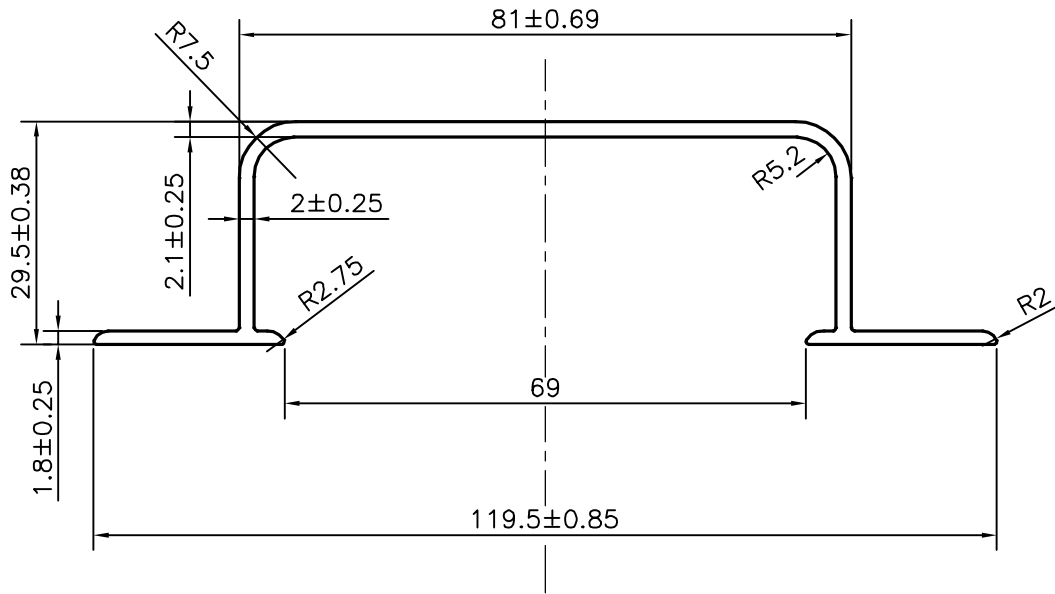

P-22985-1

18686



1. STRAIGHTNESS=1.7mm/M
2. TWIST=1.7mm/M
3. ANGULARITY= ±2°
4. FLATNESS =0.007xWIDTH

APPROXIMATE WEIGHT RANGE -0.845 - 1.033 kg/m

 SYMBOL OF QUALITY AN ISO 9001 COMPANY	JINDAL ALUMINIUM LTD. BANGALORE-560073 (INDIA)	NAME		DATE
		DRAWN	SURENDRA	23-09-2021
		CHECKED		
		APPROVED		B.NATARAJA 27-09-2021
1. ALL DIMENSIONS ARE IN mm. 2. ROUND OFF ALL SHARP CORNERS WITH 0.40 mm. 3. TOLERANCES WILL BE AS PER IS:3965-1981 , UNLESS OTHERWISE SPECIFIED		SCALE		1:1
		AREA mm ²		347.754
		PERIMETER mm.		353.328
		WEIGHT kg/m		0.939
PARTY'S NAME		IMPERIAL METAL MART, DELHI		
PARTY'S DRAWING No.		AS PER DRAWING		
ALLOY & TEMPER		HE9WP A3D		
DESCRIPTION		HANDLE SECTION		
		DRAWING No.	SECTION No.	
		P-22985-1	-	
		18686	18686	