

4130

19052

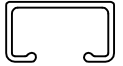

1:1

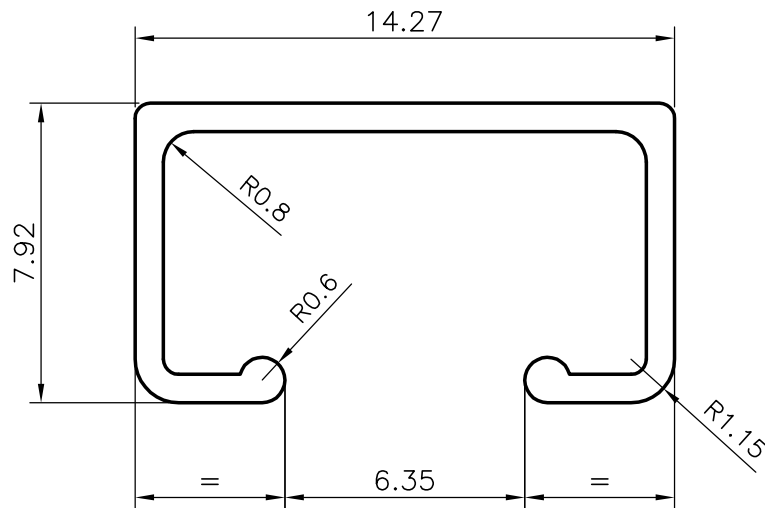

GENERAL WALL THICKNESS:- 0.75 mm.



SYMBOL OF QUALITY
AN ISO 9001 COMPANY

JINDAL ALUMINIUM LTD.
BANGALORE-560073 (INDIA)

	NAME	DATE
DRAWN	D K Shaw	04-11-03
CHECKED		
APPROVED		

1. ALL DIMENSIONS ARE IN mm.
2. ROUND OFF ALL SHARP CORNERS WITH 0.40 mm.
3. TOLERANCES WILL BE AS PER IS: 3965-1981 UNLESS OTHERWISE SPECIFIED

SCALE	5:1
AREA mm ²	26.6
PERIMETER mm.	69.4
WEIGHT kg/m	0.071

PARTY'S NAME	-	DRAWING No.	SECTION No.
PARTY'S DRAWING No.	-	4130	4130
ALLOY & TEMPER	HE9 WP	19052	19052
DESCRIPTION	CURTAIN RAIL-SPECIAL		