

4168
19162

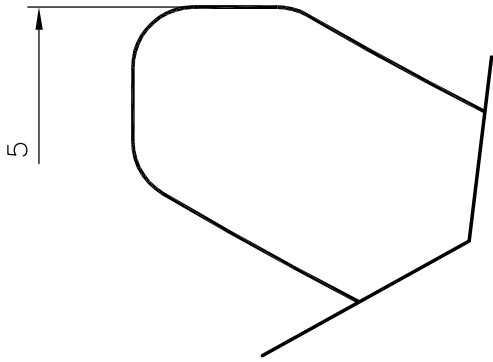

DETAILS 'A'
20:1

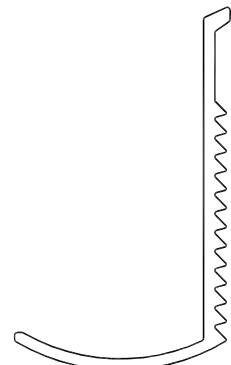

1:1

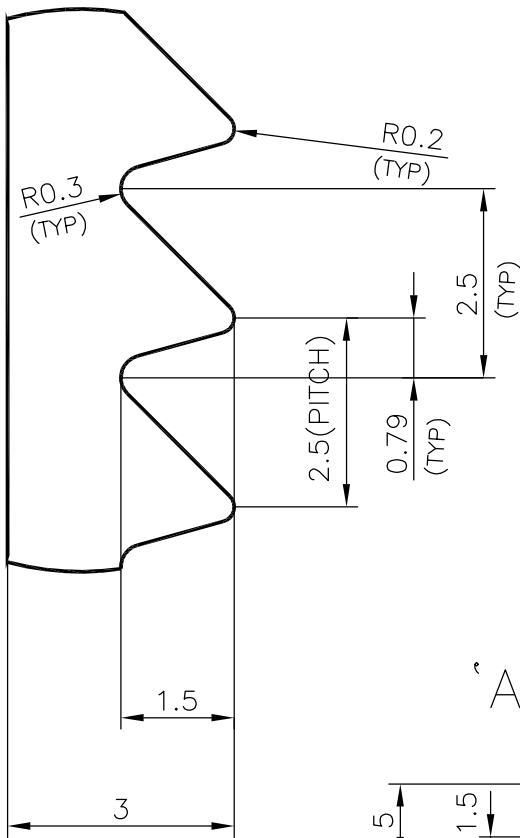

DETAILS 'B'
10:1

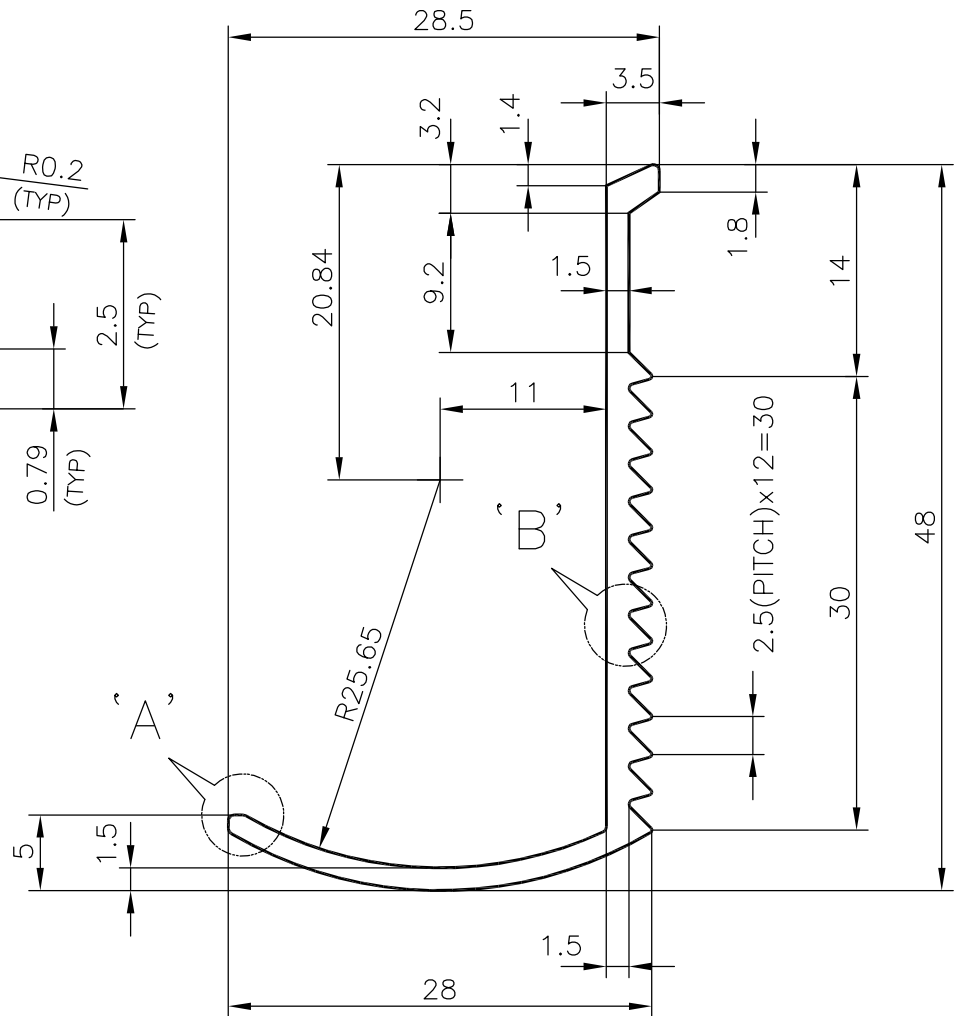

JINDAL ALUMINIUM LTD.
BANGALORE-560073

	NAME	DATE
DRAWN	P,KULKARNI	12-12-98
CHECKED		
APPROVED		

1. ALL DIMENSIONS ARE IN mm.
2. ROUND OFF ALL SHARP CORNERS WITH 0.4 mm.
3. TOLERANCES WILL BE AS PER IS: 3965-1981 ,UNLESS OTHERWISE SPECIFIED

PARTY'S NAME	ASIAN HARDWARE., COLOMBO	SCALE	2:1
PARTY'S DRAWING No.	AS PER SAMPLE	WEIGHT kg/m	0.359
ALLOY & TEMPER	HE9 WP (6063 T6)	SECTION No.	4168 19162
LENGTH	3658/5850 mm	DRAWING No.	4168 19162
DESCRIPTION	STEP NOZING		