

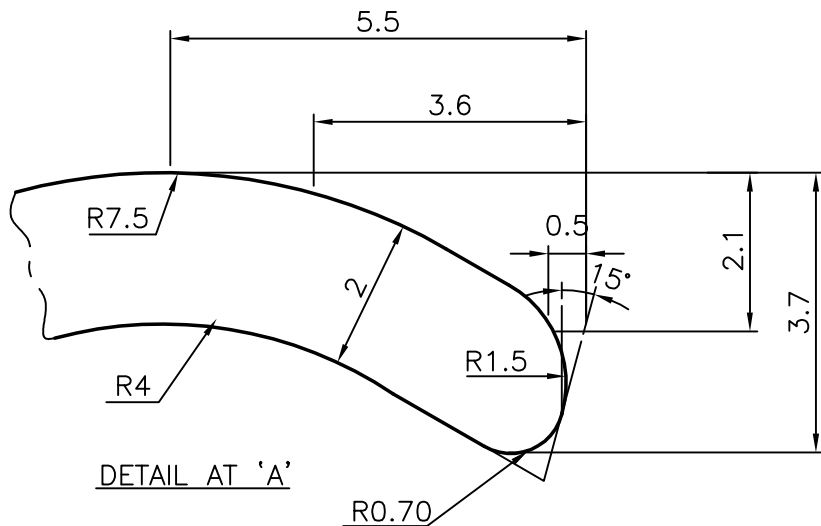

4284

14002

19204

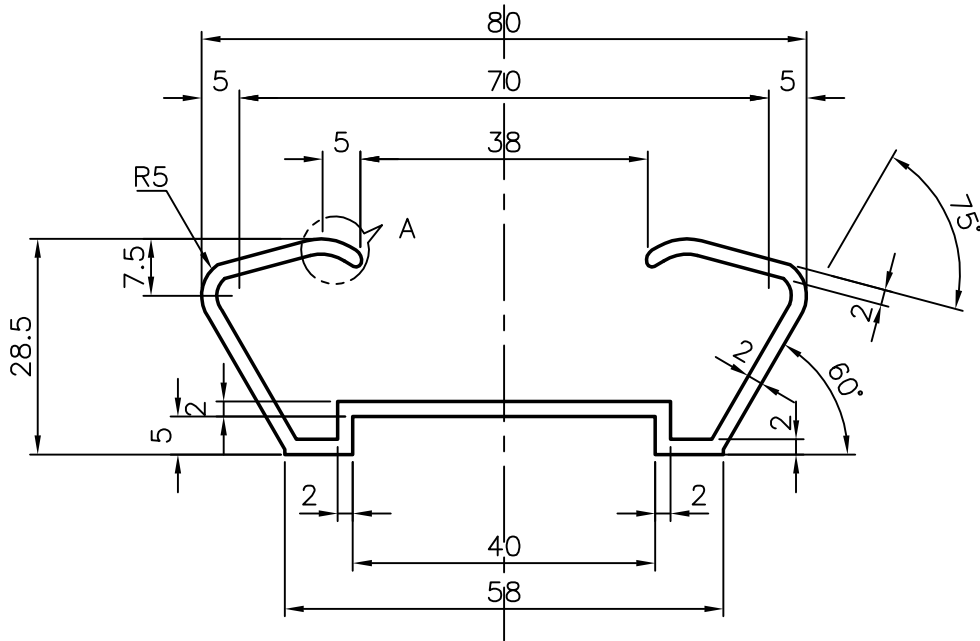

 SYMBOL OF QUALITY AN ISO 9002 COMPANY	<b>JINDAL ALUMINIUM LTD.</b> BANGALORE-560073 (INDIA)			NAME	DATE
				DRAWN	S.P.SHARMA
1. ALL DIMENSIONS ARE IN mm 2. ROUND OFF SHARP CORNERS WITH 0.4mm R 3. TOLERANCES WILL BE AS PER IS : 3965-1981				CHECKED	
				APPROVED	
				SCALE	1:1
PARTY'S NAME	-			WEIGHT kg/m	0.851
PARTY'S DRAWING No.	-	FINISH	AS EXTRUDED	SECTION No.	19204
ALLOY & TEMPER	HE 9 WP	LENGTH:	3658mm.	DRAWING No.	
DESCRIPTION	HAND RAIL			19204	