

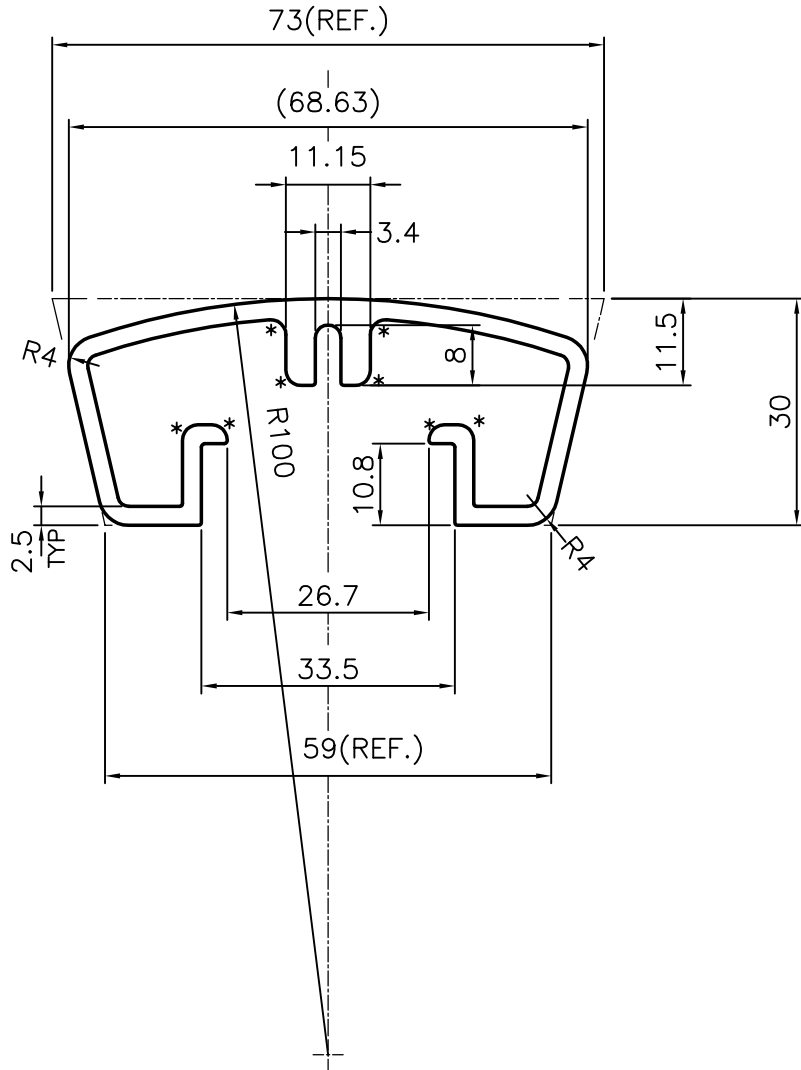

| |
|-------|
| 4287 |
| 14005 |
| 19207 |



* = R 2.0 RADIUS (8 PLACES)

| | | | | |
|--|--|----------------------|-------------|------------|
|  SYMBOL OF QUALITY AN ISO 9001 COMPANY | JINDAL ALUMINIUM LTD. BANGALORE-560073 (INDIA) | DRAWN | NAME | DATE |
| | | CHECKED | J.P.KAUSHIK | 19-11-2010 |
| | | APPROVED | | |
| 1. ALL DIMENSIONS ARE IN mm. 2. ROUND OFF ALL SHARP CORNERS WITH 0.40 mm. 3. TOLERANCES WILL BE AS PER,IS:3965-1981 UNLESS OTHERWISE SPECIFIED | | SCALE | | 1:1 |
| | | AREA mm ² | | 474.624 |
| | | PERIMETER mm. | | 351.554 |
| PARTY'S NAME | | WEIGHT kg/m | | 1.281 |
| | | DRAWING No. | SECTION No. | |
| PARTY'S DRAWING No. | | 4287 | 4287 | |
| | | 14007 | 14007 | |
| ALLOY & TEMPER | | 19207 | 19207 | |
| | | | | |
| DESCRIPTION | | HAND RAIL SECTION | | |
| | | | | |