

4307

14017

19224

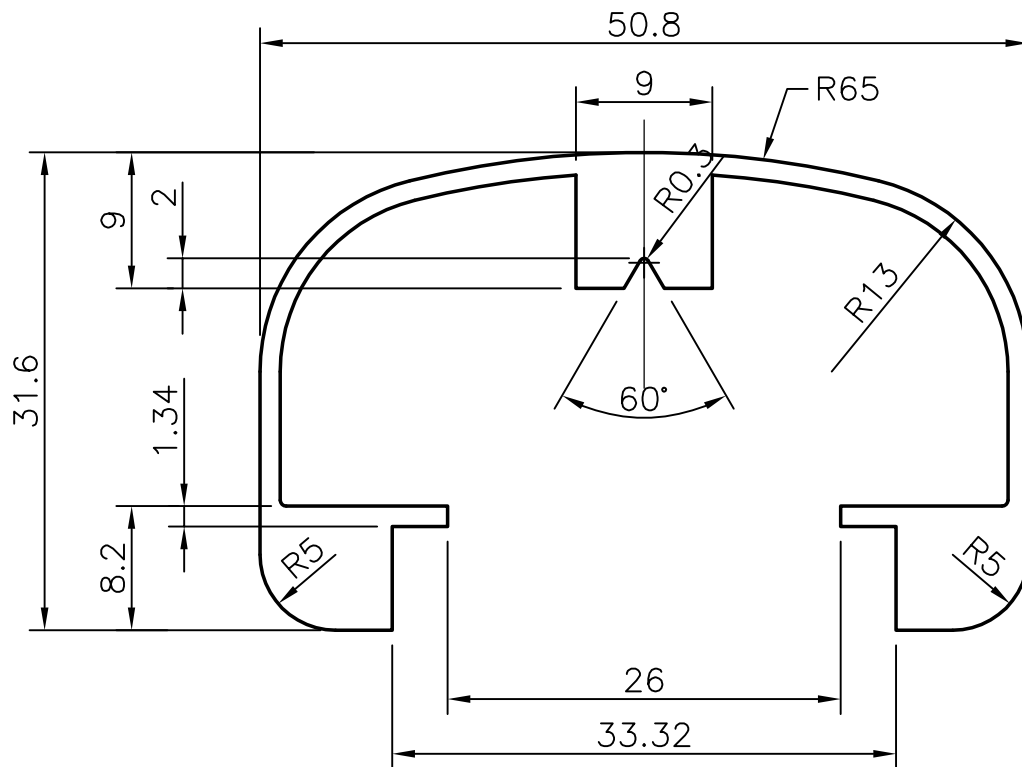
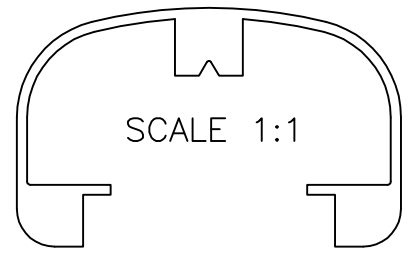

1. GENERAL WALL THICKNESS:- 1.34 mm.
2. 3658 mm. LONG PIECES IN 100 kgs:- 32 (AVERAGE)



SYMBOL OF QUALITY
AN ISO 9001 COMPANY

JINDAL ALUMINIUM LTD.
BANGALORE-560073 (INDIA)

	NAME	DATE
DRAWN	RAGHAVENDRA	25-11-01
CHECKED		
APPROVED		

1. ALL DIMENSIONS ARE IN mm.
2. ROUND OFF ALL SHARP CORNERS WITH 0.40 mm.
3. TOLERANCES WILL BE AS PER IS: 3965-1981 UNLESS OTHERWISE SPECIFIED

SCALE	2:1 & 1:1
-------	-----------

AREA mm ²	317.26
----------------------	--------

PERIMETER mm.	255.28
---------------	--------

PARTY'S NAME

-

PARTY'S DRAWING No.

LIGHTER OF 4286

WEIGHT kg/m

0.855

ALLOY & TEMPER

HE9 WP

SECTION No.

19224

DESCRIPTION

HAND RAIL

DRAWING No.

19224